

VIEW B-B

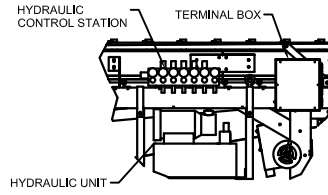

DETAIL C
HYDRAULIC CONTROLS

NOTES:

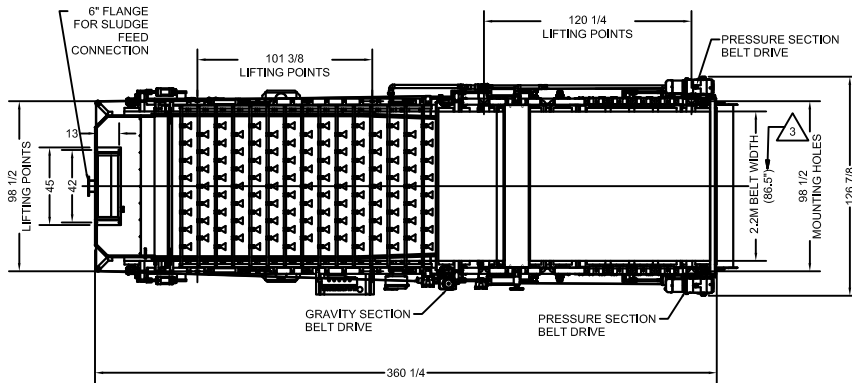
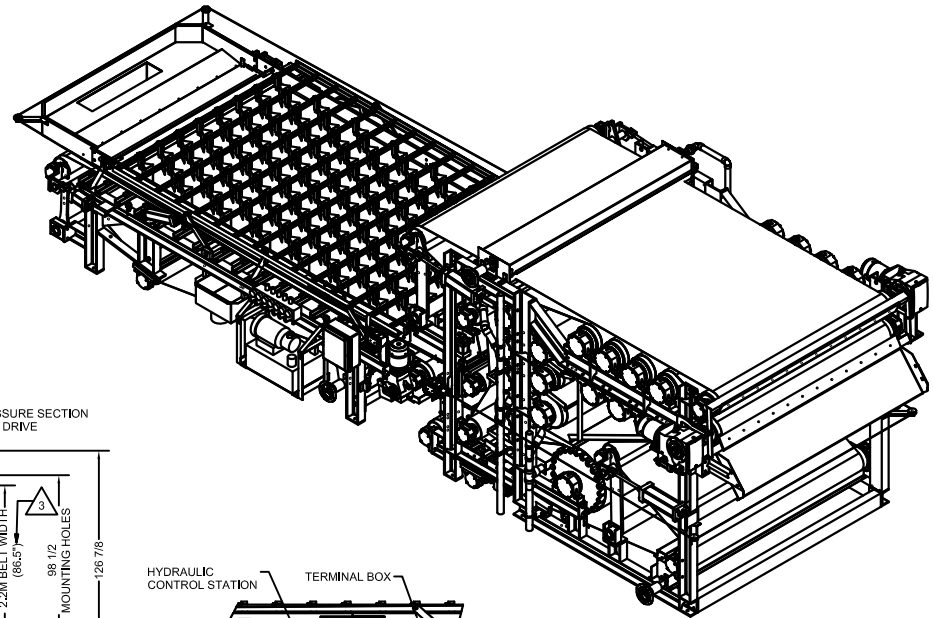

LIFTING POINTS ARE MIN 1 1/4" DIA FOR ALL LOCATIONS

LOCATION OF PLANT WATER CONNECTION FOR BELT WASH SYSTEM VARIES ACC. TO LOCATION OF WASH WATER BOOSTER PUMP AND USE OF OPTIONAL WASH WATER RECYCLE.

GBT SECTION DRY WEIGHT = 6,100 LBS
GBT SECTION WET WEIGHT = 7,750 LBS

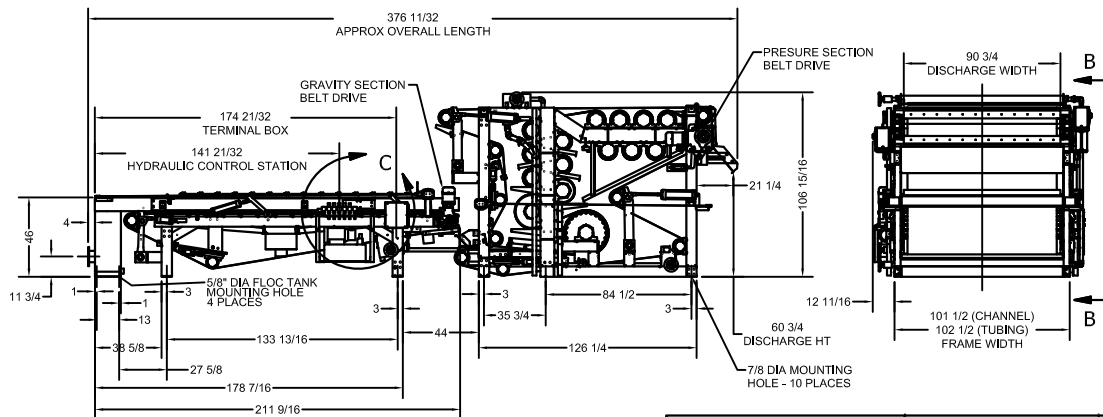
PRESSURE SECTION DRY WEIGHT = 16,200 LBS
PRESSURE SECTION WET WEIGHT = 17,800 LBS

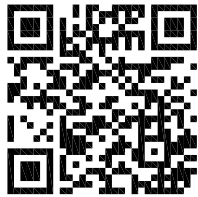

		DRAWN TMP APPROVED	CHARTER MACHINE COMPANY 55 WESTER AVE METUCHEN N.J. 08840		
		G.E.C. TOLERANCES UNLESS OTHERWISE SPECIFIED FRACTIONAL DIM ±1/64 DECIMAL DIM ±.005 ANGLE ± 1/2 SURFACE FINISH 125	TITLE THREE BELT TOWER PRESS TP22.594SH MACHINE VIEWS		SIZE
WEBSITE DOWNLOADS ARE FOR REFERENCE ONLY. CONTACT SALES FOR FURTHER INFO.		SCALE NONE		SHEET 1 OF 1	