

DETAIL B
HYDRAULIC CONTROLS

NOTES:
 ALL DIMENSIONS ARE IN INCHES
 LIFTING POINTS ARE MIN, 1 1/4" DIA FOR ALL LOCATIONS
 LOCATION OF PLANT WATER CONNECTION FOR BELT WASH SYSTEM VARIES ACC. TO LOCATION OF WASH WATER BOOSTER PUMP AND USE OF OPTIONAL WASH WATER RECYCLE.
 APPROXIMATE DRY WEIGHT = 29,000 LBS
 APPROXIMATE WET WEIGHT = 32,000 LBS
 2 PIECE FRAME DESIGN

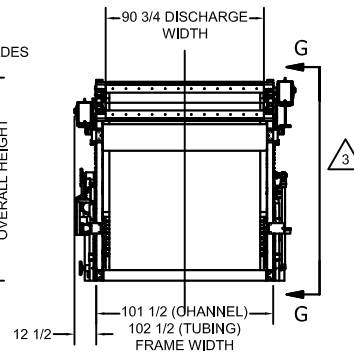
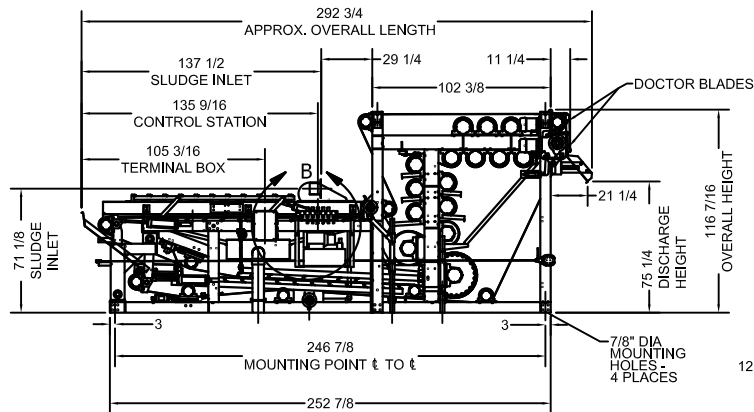

DRAWN	TMP
APPROVED	
G.E.C. TOLERANCES UNLESS OTHERWISE SPECIFIED	
FRACTIONAL DIM	±1/64
DECIMAL DIM	±.005
ANGLE	± 1/2
SURFACE FINISH	125

CHARTER MACHINE COMPANY		
55 WESTER AVE METUCHEN N.J. 08840		
TITLE TOWER PRESS TP22.54SH		
MACHINE VIEWS		
SIZE	DWG. NO. TP22.54SH-02	REV 3
SCALE	NONE	SHEET 1 OF 1

WEBSITE DOWNLOADS ARE FOR REFERENCE ONLY. CONTACT SALES FOR FURTHER INFO.

PROPRIETARY: EXCEPT AS OTHERWISE AGREED IN WRITING, THE INFORMATION AND DESIGN DISCLOSED HEREIN ARE THE PROPERTY OF THE CHARTER MACHINE COMPANY AND MUST NOT BE COPIED OR DISTRIBUTED OUTSIDE THE CHARTER MACHINE COMPANY EXCEPT TO AUTHORIZED PERSONS WITH A GENUINE NEED TO KNOW WHO BY THE USE HEREOF ACKNOWLEDGE CHARTER MACHINE COMPANY OWNERSHIP AND AGREE TO MAINTAIN THIS INFORMATION AND DESIGN IN STRICT CONFIDENCE.