

VIEW B-B

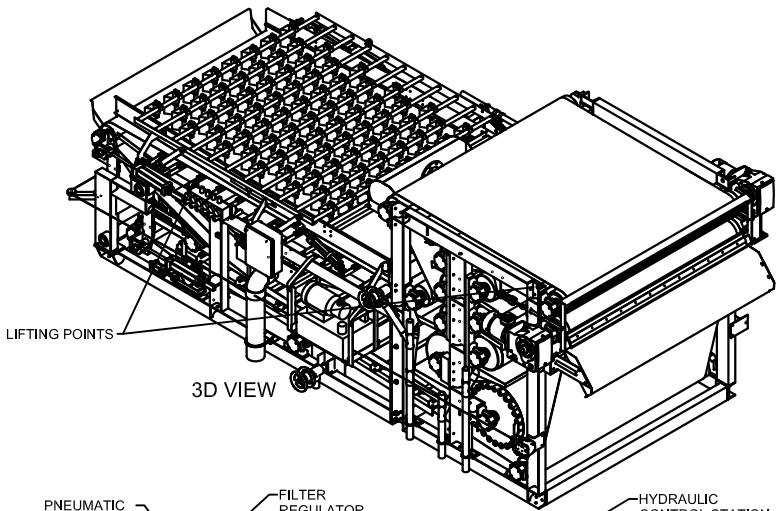

3D VIEW

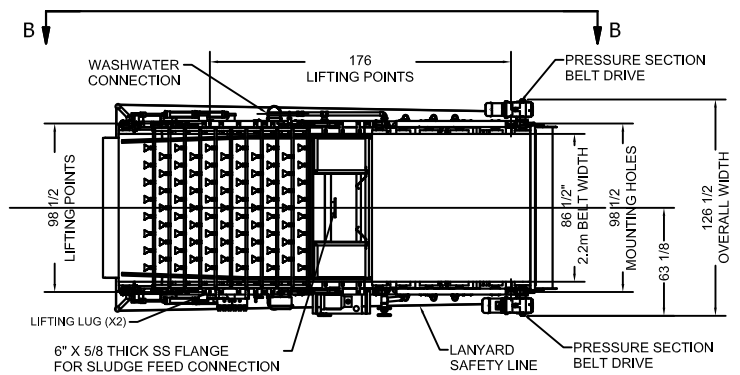
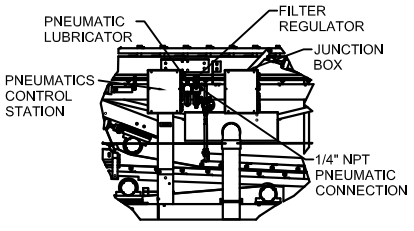

DETAIL C PNEUMATIC CONTROLS

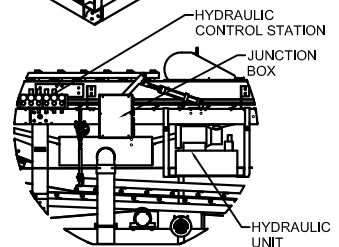

DETAIL C HYDRAULIC CONTROLS

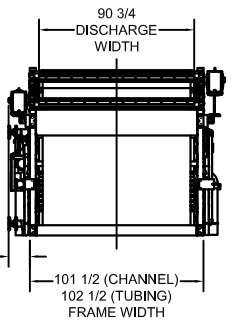
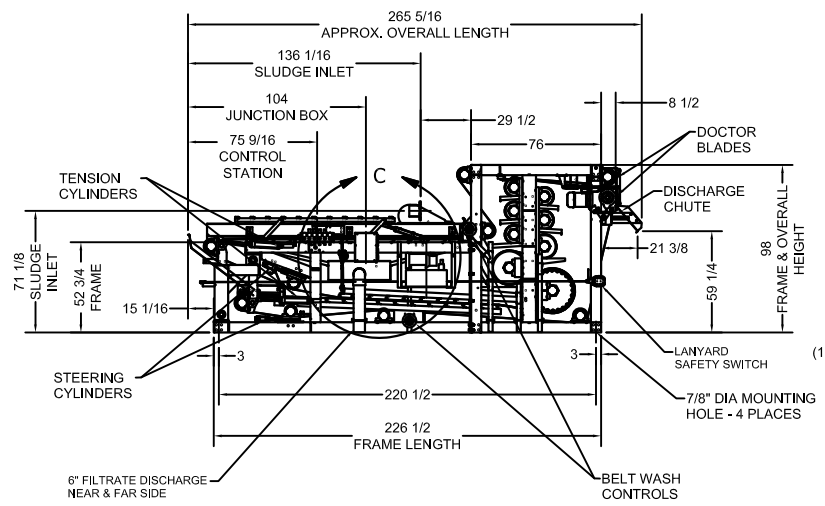

NOTES:
 DETAIL C WILL VARY DEPENDING ON IF SYSTEM UTILIZES PNEUMATICS OR HYDRAULICS
 ALL DIMENSIONS ARE IN INCHES
 LIFTING POINTS ARE MIN 1 1/4" DIA FOR ALL LOCATIONS
 LOCATION OF PLANT WATER CONNECTION FOR BELT WASH SYSTEM VARIES ACCORDING TO LOCATION OF WASH WATER BOOSTER PUMP AND USE OF OPTIONAL WASH WATER RECYCLE.
 APPROXIMATE DRY WEIGHT - 23,000 LBS
 APPROXIMATE WET WEIGHT - 25,000 LBS
 2 PIECE FRAME DESIGN

WEBSITE DOWNLOADS ARE FOR REFERENCE ONLY. CONTACT SALES FOR FURTHER INFO.



| | |
|--|-------|
| DRAWN | TMP |
| APPROVED | |
| G.E.C. TOLERANCES UNLESS OTHERWISE SPECIFIED | |
| FRACTIONAL DIM | ±1/64 |
| DECIMAL DIM | ±.005 |
| ANGLE | ± 1/2 |
| SURFACE FINISH | 125 |

| | | |
|-----------------------------------|-------------------------|--------------|
| CHARTER MACHINE COMPANY | | |
| 55 WESTER AVE METUCHEN N.J. 08840 | | |
| TITLE TOWER PRESS TP22.44S | | |
| MACHINE VIEWS | | |
| SIZE | DWG. NO. TP22.44S-02 | REV 2 |
| SCALE | NONE | SHEET 1 OF 1 |

PROPRIETARY: EXCEPT AS OTHERWISE AGREED IN WRITING, THE INFORMATION AND DESIGN DISCLOSED HEREIN ARE THE PROPERTY OF THE CHARTER MACHINE COMPANY AND MUST NOT BE COPIED OR DISTRIBUTED OUTSIDE THE CHARTER MACHINE COMPANY EXCEPT TO AUTHORIZED PERSONS WITH A GENUINE NEED TO KNOW WHO BY THE USE HEREOF ACKNOWLEDGE CHARTER MACHINE COMPANY OWNERSHIP AND AGREE TO MAINTAIN THIS INFORMATION AND DESIGN IN STRICT CONFIDENCE.