

**NOTE:**

- 1) APPROX. WEIGHT -- 900 LBS.
- 2) DIMENSIONS ARE APPROXIMATE

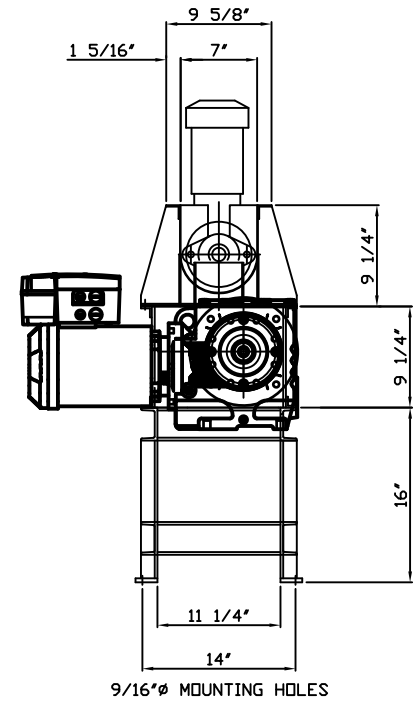
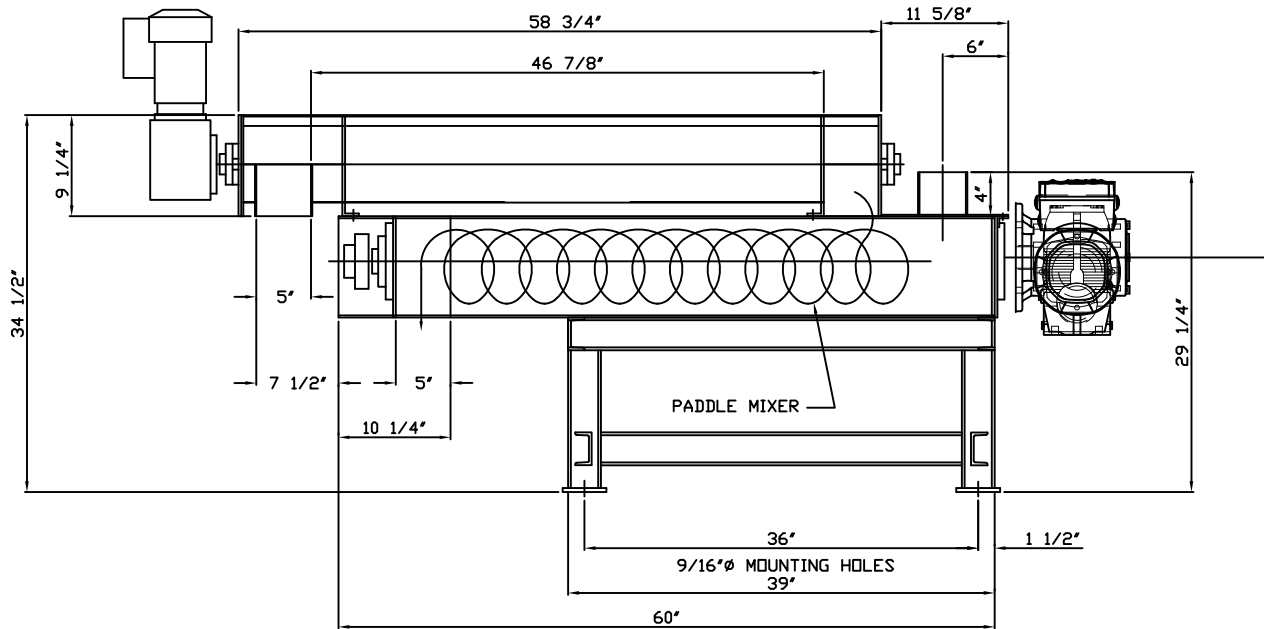

DRAWN	
TEMP	
APPROVED	
<b>G.E.C. TOLERANCES UNLESS OTHERWISE SPECIFIED</b>	
FRACTIONAL DIM	±1/64
DECIMAL DIM	±.005
ANGLE	± 1/2
SURFACE FINISH	125

CHARTER MACHINE COMPANY		
55 WESTER AVE METUCHEN N.J. 08840		
TITLE LIME POST TREATMENT UNIT RDEMIX 150 - END MOUNT MACHINE VIEWS		
SIZE	DWG NO.	REV
B	RM150E-02	1
SCALE	NONE	SHEET 1 OF 1

WEBSITE DOWNLOADS ARE FOR REFERENCE ONLY. CONTACT SALES FOR FURTHER INFO.

PROPRIETARY: EXCEPT AS OTHERWISE AGREED IN WRITING, THE INFORMATION AND DESIGN DISCLOSED HEREIN ARE THE PROPERTY OF THE CHARTER MACHINE COMPANY AND MUST NOT BE COPIED OR DISTRIBUTED OUTSIDE THE CHARTER MACHINE COMPANY EXCEPT TO AUTHORIZED PERSONS WITH A GENUINE NEED TO KNOW WHO BY THE USE HEREOF ACKNOWLEDGE CHARTER MACHINE COMPANY OWNERSHIP AND AGREE TO MAINTAIN THIS INFORMATION AND DESIGN IN STRICT CONFIDENCE.