

BP 6000TM

Horizontal Belt Press

Superior Performance

High-Quality

Maximum Efficiency



 **Charter Machine
Company**

BP 6000 Series Horizontal Belt Press For Municipal And Industrial Applications

Engineered For Performance... American Built To Last.

BP 6000 – Tradition And Performance

The 6000 Series is Charter Machine's version of the traditional horizontal belt filter press. As with all our models the moment of inertia (frame strength), safety factors and deflections on our horizontal design are among the highest in the industry.

Charter strives to meet the needs of their clients whether it is the typical hot-dipped galvanized frame with stainless steel components or complete stainless steel models. In addition to the standard size horizontal press we also offer a short-deck model for the shorter footprint but still maintain all the features and benefits of the original model.



BP 6000 with optional wire guard. Charter can customize their equipment to meet the client's particular needs. Our in-house engineering staff can provide assistance in design, layout, drawings and controls to meet any situation.

Stainless steel belt wash station internal brush system with hand wheel operated flush design.



Save Money And Time

Skid Mount Systems – The All In One Solution

Charter Machine offers skid mounted systems that can be customized to meet any facility's needs. Our sump/skid systems can include the belt filter press only or be a complete "plug and play" system combining any combination of sludge feed pump, compressor, booster pump, in-line mixer, polymer system, conveyors, and control panel.

Pneumatic or hydraulic control station capable of up to 75 pli design.



Belt Tensioning

Pneumatic / Hydraulically controlled rigid tensioning assembly adjusts and maintains belt tension with parallel movement for extended belt life.

Center Pivot Tracking

Charter Machine utilizes a Pneumatic / Hydraulic controlled center pivot alignment system. This design reduces belt stretching, lengthens belt life and provides a more consistent performance over the life of the belt.



One Piece Bearings

Charter Machine utilizes Rilsan Nylon coated one-piece solid pillow block bearing housings with gasketed end plate. Self-aligning double-row spherical bearings with quadruple lip seals. The contact surface of the shafts shall have a 60 micrometer polished finish to increase seal life and each stub shaft shall be held in place with a lock ring to guarantee alignment.

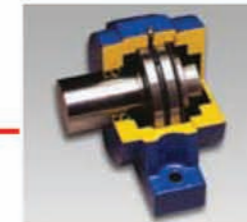

BP6000 HS (12 Roll)

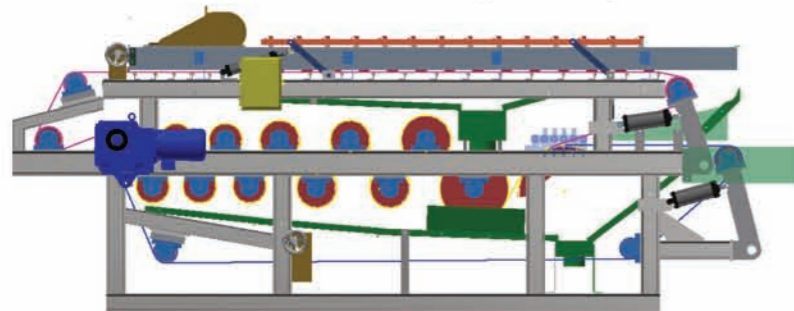

Our BP6000 HS (High Solid) 12 Roll is an enlarged version of the BP6000. Four additional rollers (12 total) provide more retention time, allowing for additional shearing and pressure. Depending on the solids processed, this could increase cake solids by 2 to 5 percent.

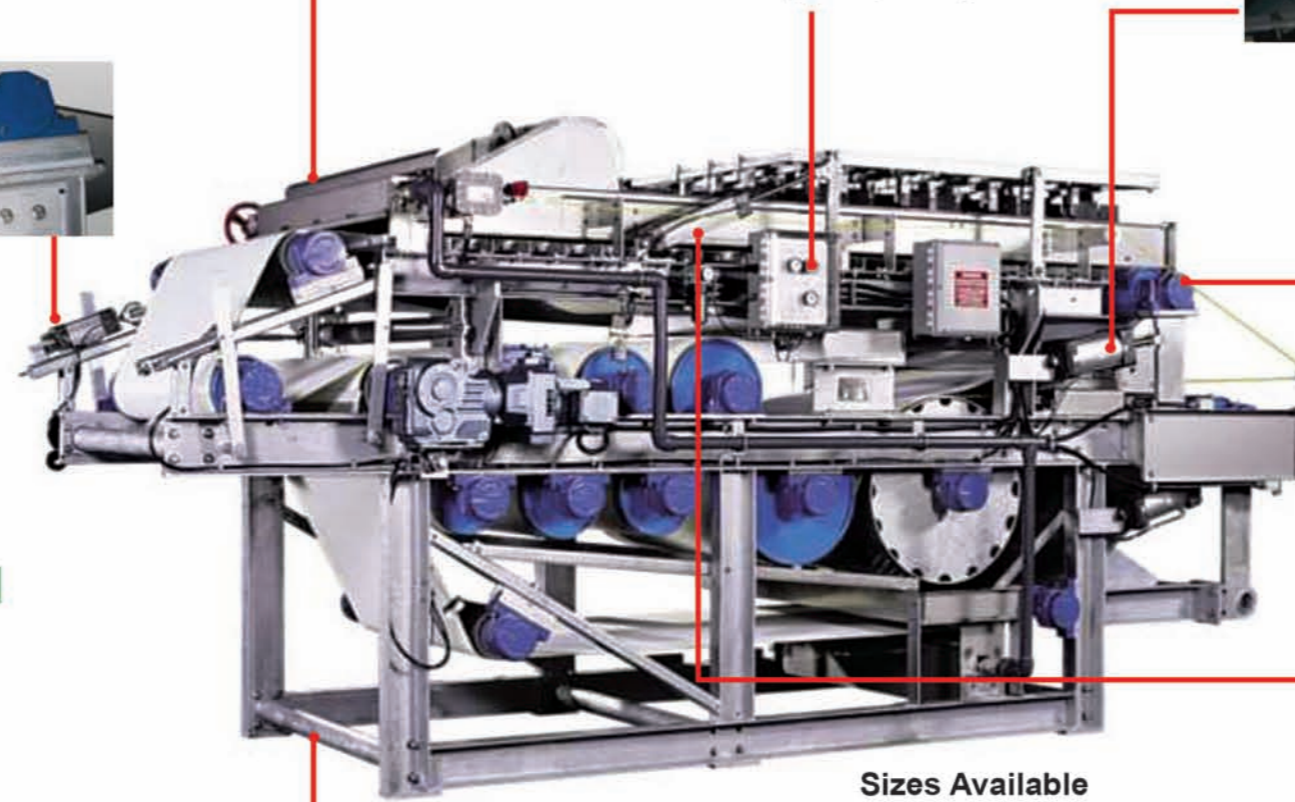

Non-corrosive construction. Hot dipped galvanized or 304, 316 S.S. available.

Sizes Available

1.2 meter
1.7 meter
2.2 meter

Plow Grid

Pneumatic / Hydraulic actuator lifts or lowers entire plow assembly for easier cleaning, eliminating manually lifting each row of plows. Plows "float" on belt and can be replaced without the use of tools.



Seamless Solutions for Biosolids Handling and Treatment.



Sentry Press
The Next Generation of 3 Belt Press

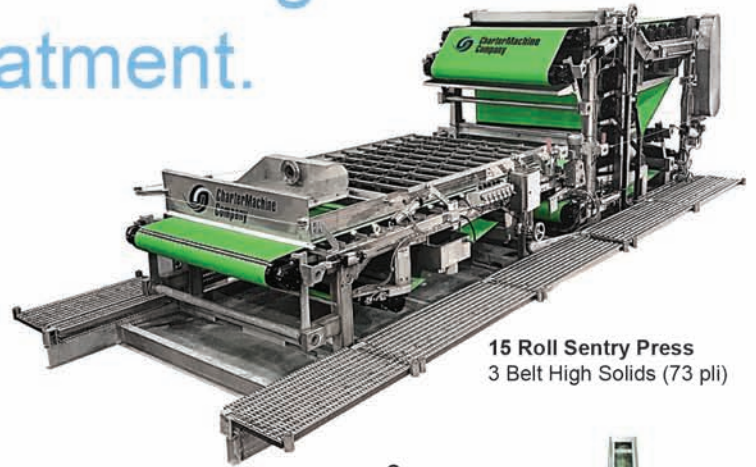

15 Roll Sentry Press
3 Belt High Solids (73 pli)

Rodrum RF90
Rotary Drum Thickener



Gravity Belt Thickener
Effective, Affordable

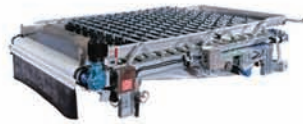

Dewatering Trailers



Conveyors
To Suit Your Needs



TP7.4 Tower Press
Smaller Capacity, Big Capabilities



L-2 Polymer
Simple Cost Effective



Roedos VI
Customized Dry Polymer System



Roemix LFS 1200
Lime Storage Feeder



Roemix RM 240
Paddle Mixer Unit

Whether its dewatering, thickening, polymer addition, conveyance or lime stabilization, Charter Machine provides customized and integrated biosolids solutions.

With our in-house staff of design engineers, we have complete control over the design, fabrication and start-up of biosolids systems perfectly suited to your operation. As a result, we can provide seamless total system responsibility -- from sludge testing, to design assistance to equipment start-up and training.

Occasionally our equipment will need servicing. At Charter Machine Company we maintain a complete inventory of replacement parts ready for immediate shipment. Assistance is a phone call away with help in troubleshooting and problem solving. Technicians are available for on-site visits.

We strive very hard to meet all your biosolids processing needs and would welcome the opportunity to be of service.

Over six decades of precision machine manufacturing.



55 Wester Avenue, Metuchen, New Jersey 08840
732-494-5350 • FAX 732-494-4596 • www.chartermachine.com