

NOTES:  
 STATIC (DRY) WEIGHT = 24,000 LBS.  
 DYNAMIC (WET) WEIGHT = 26,000 LBS.

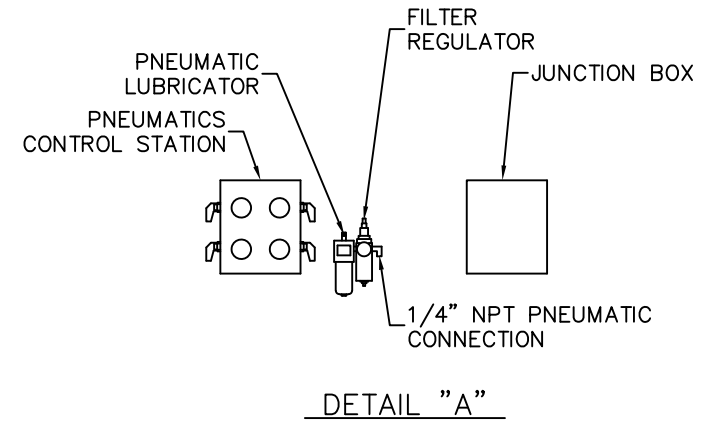

WEBSITE DOWNLOADS ARE FOR REFERENCE ONLY. CONTACT SALES FOR FURTHER INFO.

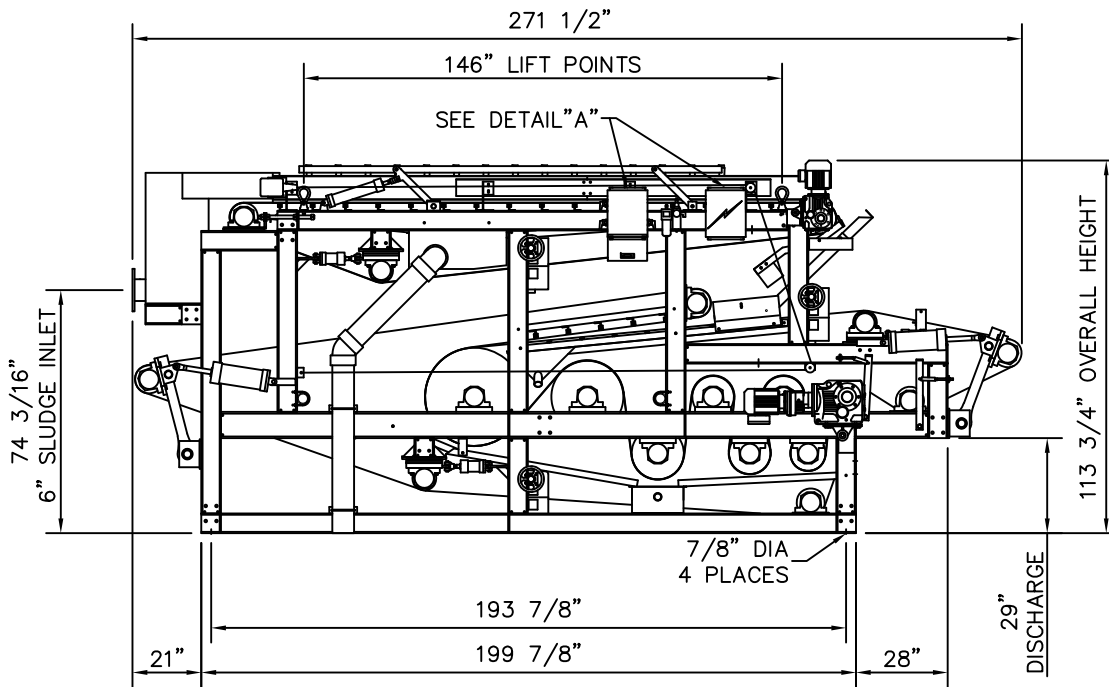

DRAWN TMP		CHARTER MACHINE COMPANY	
APPROVED		55 WESTER AVE METUCHEN N.J. 08840	
G.E.C. TOLERANCES UNLESS OTHERWISE SPECIFIED		TITLE BELT PRESS 22.83	
FRACTIONAL DIM $\pm 1/64$		MACHINE VIEWS	
DECIMAL DIM $\pm 0.05$		SIZE	DWG NO. BP22.83-02A
ANGLE $\pm 1/2$			REV 2
SURFACE FINISH 125		SCALE NONE	SHEET 1 OF 1

PROPRIETARY: EXCEPT AS OTHERWISE AGREED IN WRITING, THE INFORMATION AND DESIGN DISCLOSED HEREIN ARE THE PROPERTY OF THE CHARTER MACHINE COMPANY AND MUST NOT BE COPIED OR DISTRIBUTED OUTSIDE THE CHARTER MACHINE COMPANY EXCEPT TO AUTHORIZED PERSONS WITH A GENUINE NEED TO KNOW WHO BY THE USE HEREOF ACKNOWLEDGE CHARTER MACHINE COMPANY OWNERSHIP AND AGREE TO MAINTAIN THIS INFORMATION AND DESIGN IN STRICT CONFIDENCE.