

NOTES:
 STATIC (DRY) WEIGHT = 19,800 LBS.
 DYNAMIC (WET) WEIGHT = 22,200 LBS.

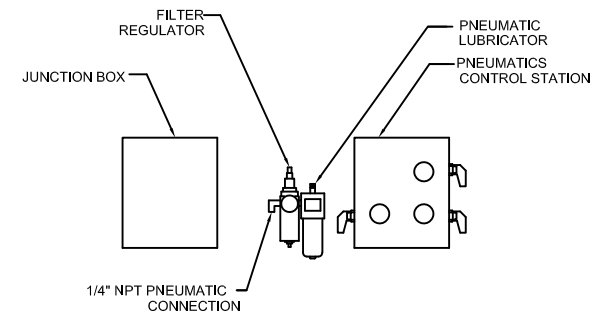

DETAIL "A"

WEBSITE DOWNLOADS ARE FOR REFERENCE ONLY. CONTACT SALES FOR FURTHER INFO.

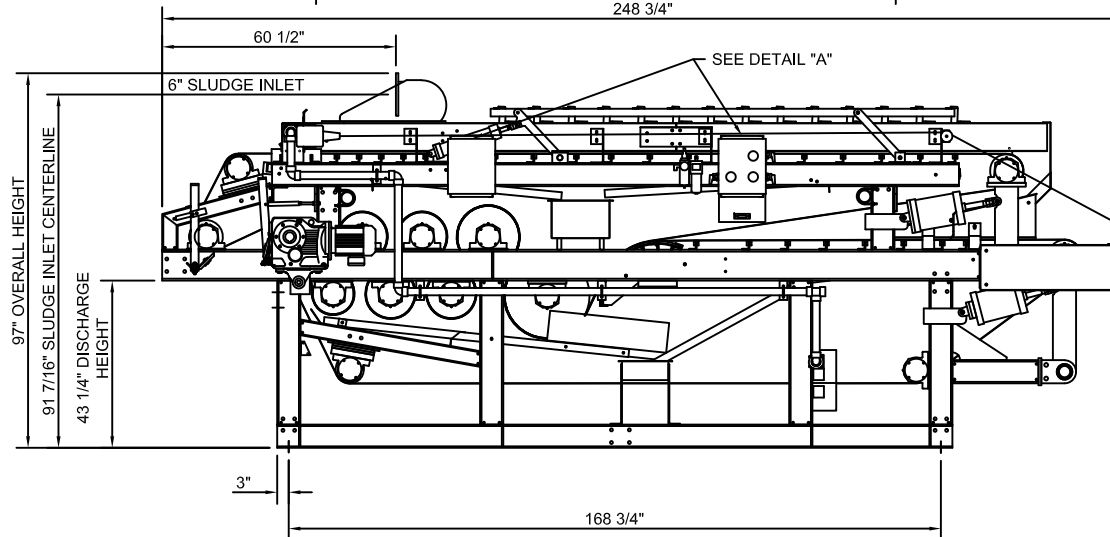

DRAWN TMP	
APPROVED	
G.E.C. TOLERANCES UNLESS OTHERWISE SPECIFIED	
FRACTIONAL DIM	±1/64
DECIMAL DIM	±.005
ANGLE	± 1/2
SURFACE FINISH	125

CHARTER MACHINE COMPANY 55 WESTER AVE METUCHEN N.J. 08840		
TITLE BELT PRESS 22.63 WITH PERFORATED GRID MACHINE VIEWS		
SIZE	DWG NO. BP22.63-B-912	REV 2
SCALE	NONE	SHEET 1 OF 1

PROPRIETARY: EXCEPT AS OTHERWISE AGREED IN WRITING, THE INFORMATION AND DESIGN DISCLOSED HEREIN ARE THE PROPERTY OF THE CHARTER MACHINE COMPANY AND MUST NOT BE COPIED OR DISTRIBUTED OUTSIDE THE CHARTER MACHINE COMPANY EXCEPT TO AUTHORIZED PERSONS WITH A GENUINE NEED TO KNOW WHO BY THE USE HEREOF ACKNOWLEDGE CHARTER MACHINE COMPANY OWNERSHIP AND AGREE TO MAINTAIN THIS INFORMATION AND DESIGN IN STRICT CONFIDENCE.