

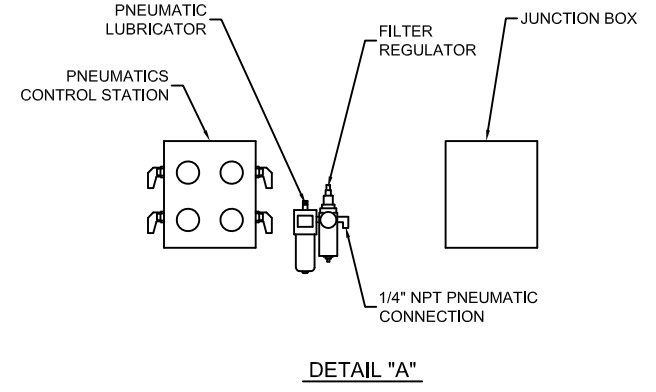

NOTES:
 STATIC (DRY) WEIGHT = 18,000 LBS.
 DYNAMIC (WET) WEIGHT = 20,000 LBS.

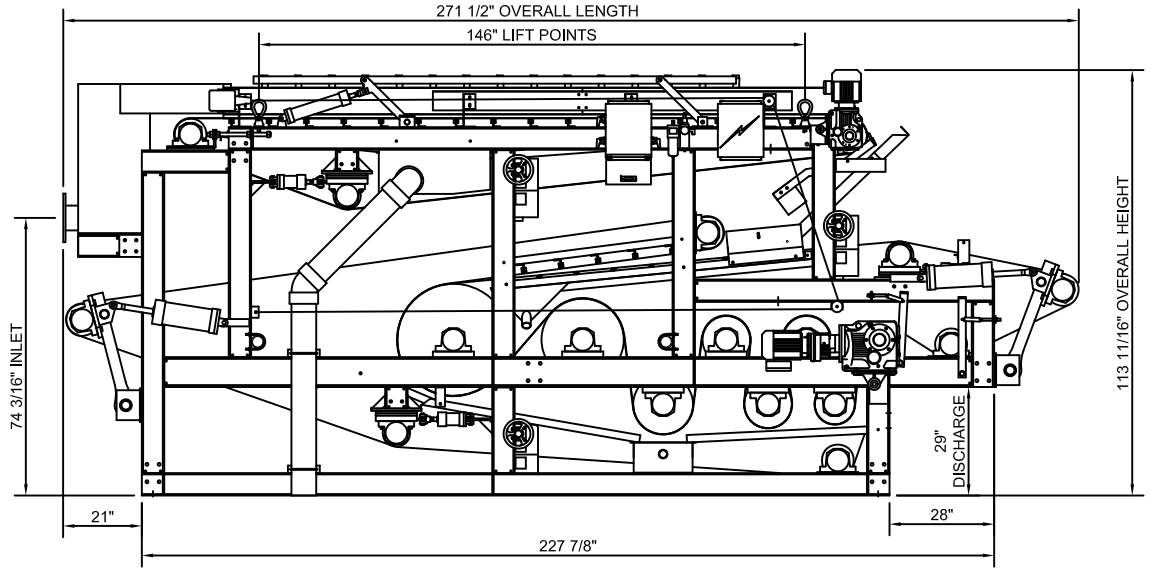

WEBSITE DOWNLOADS ARE FOR REFERENCE ONLY. CONTACT SALES FOR FURTHER INFO.

		DRAWN TMP		CHARTER MACHINE COMPANY 55 WESTER AVE METUCHEN N.J. 08840	
		APPROVED			
G.E.C. TOLERANCES UNLESS OTHERWISE SPECIFIED		FRACTIONAL DIM $\pm 1/64$ DECIMAL DIM $\pm .005$ ANGLE $\pm 1/2$ SURFACE FINISH 125		TITLE BELT PRESS 12.83	
		MACHINE VIEWS		SIZE	DWG NO. BP12.83A-02
		SCALE NONE		SHEET 1 OF 1	REV 1

PROPRIETARY: EXCEPT AS OTHERWISE AGREED IN WRITING, THE INFORMATION AND DESIGN DISCLOSED HEREIN ARE THE PROPERTY OF THE CHARTER MACHINE COMPANY AND MUST NOT BE COPIED OR DISTRIBUTED OUTSIDE THE CHARTER MACHINE COMPANY EXCEPT TO AUTHORIZED PERSONS WITH A GENUINE NEED TO KNOW WHO BY THE USE HEREOF ACKNOWLEDGE CHARTER MACHINE COMPANY OWNERSHIP AND AGREE TO MAINTAIN THIS INFORMATION AND DESIGN IN STRICT CONFIDENCE.