

DETAIL "A"

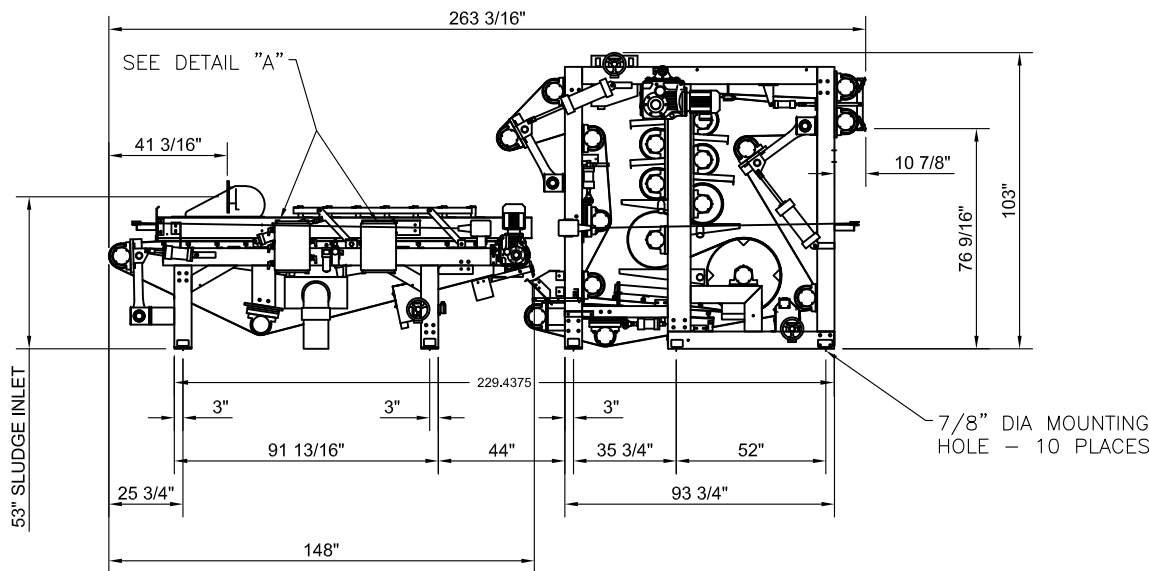

NOTES:

LOCATION OF PLANT WATER CONNECTION FOR BELT WASH SYSTEM VARIES ACCORDING TO LOCATION OF WASH WATER BOOSTER PUMP AND USE OF OPTIONAL WASH WATER RECYCLE.

LIFTING POINTS ARE MIN. 1 1/4" DIA FOR ALL LOCATIONS.

GBT SECTION DRY WEIGHT = 5,500 LBS.
GBT SECTION WET WEIGHT = 6,700 LBS.

PRESSURE SECTION DRY WEIGHT = 14,350 LBS.
PRESSURE SECTION WET WEIGHT = 15,900 LBS.

WEBSITE DOWNLOADS ARE FOR REFERENCE ONLY. CONTACT SALES FOR FURTHER INFO.



DRAWN	
TMP	
APPROVED	
G.E.C. TOLERANCES UNLESS OTHERWISE SPECIFIED	
FRACTIONAL DIM	±1/64
DECIMAL DIM	±.005
ANGLE	± 1/2
SURFACE FINISH	125

CHARTER MACHINE COMPANY		
55 WESTER AVE METUCHEN N.J. 08840		
TITLE THREE BELT TOWER PRESS 22.92S		
MACHINE VIEWS		
SIZE	DWG NO. 3BTP22.92S-02	REV 0
SCALE	NONE	SHEET 1 OF 1