

NOTE: MINIMUM 20 GPM @ 30 PSI WATER SUPPLY REQUIRED
 TOTAL WEIGHT MINUS DRUM - 382lbs

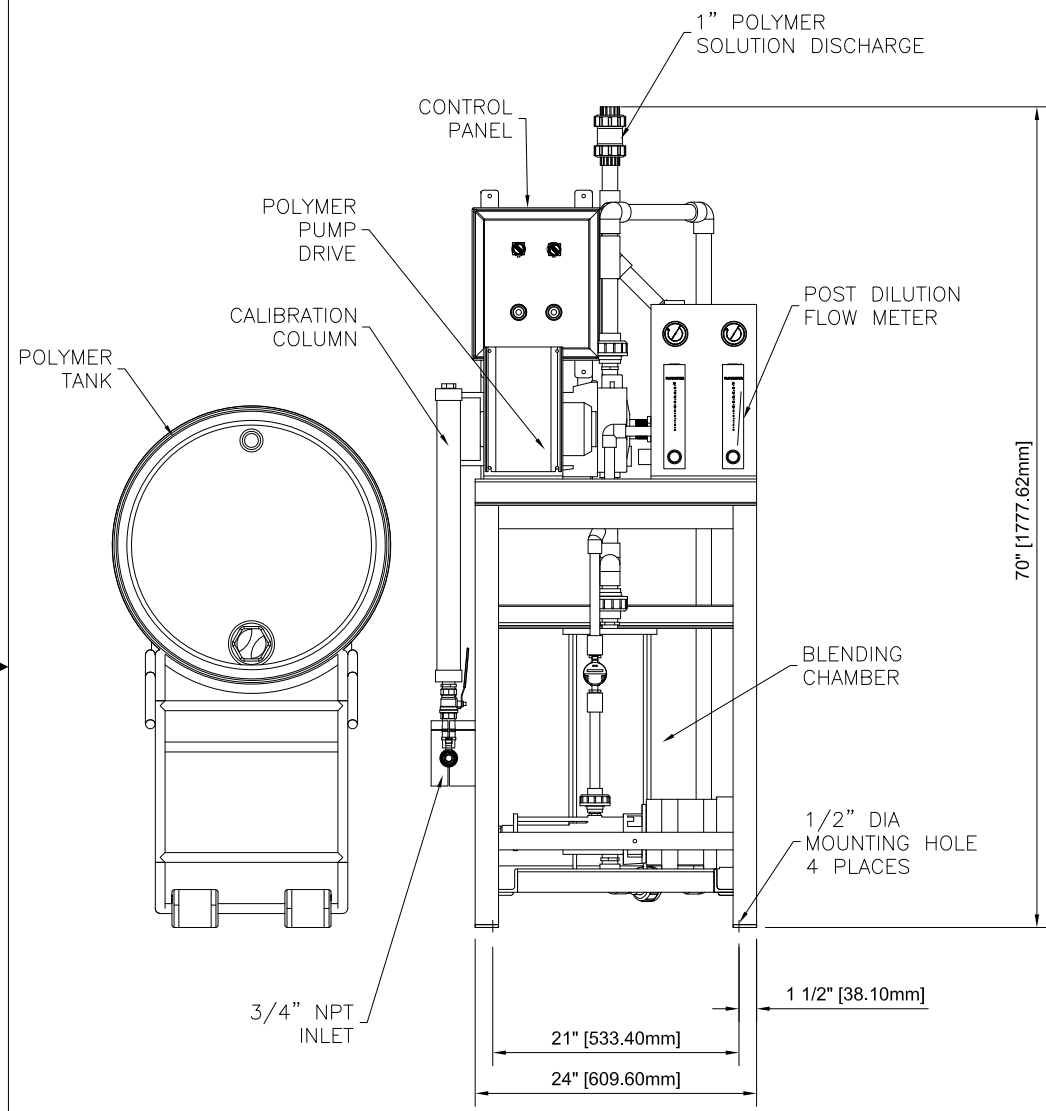

FRONT

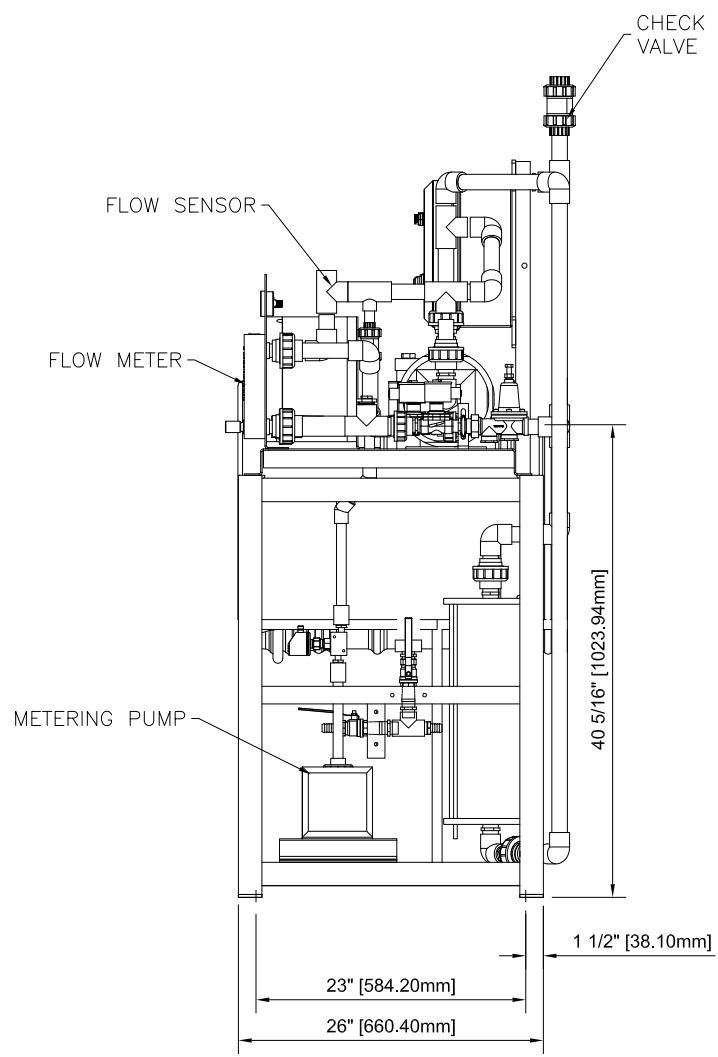

SIDE

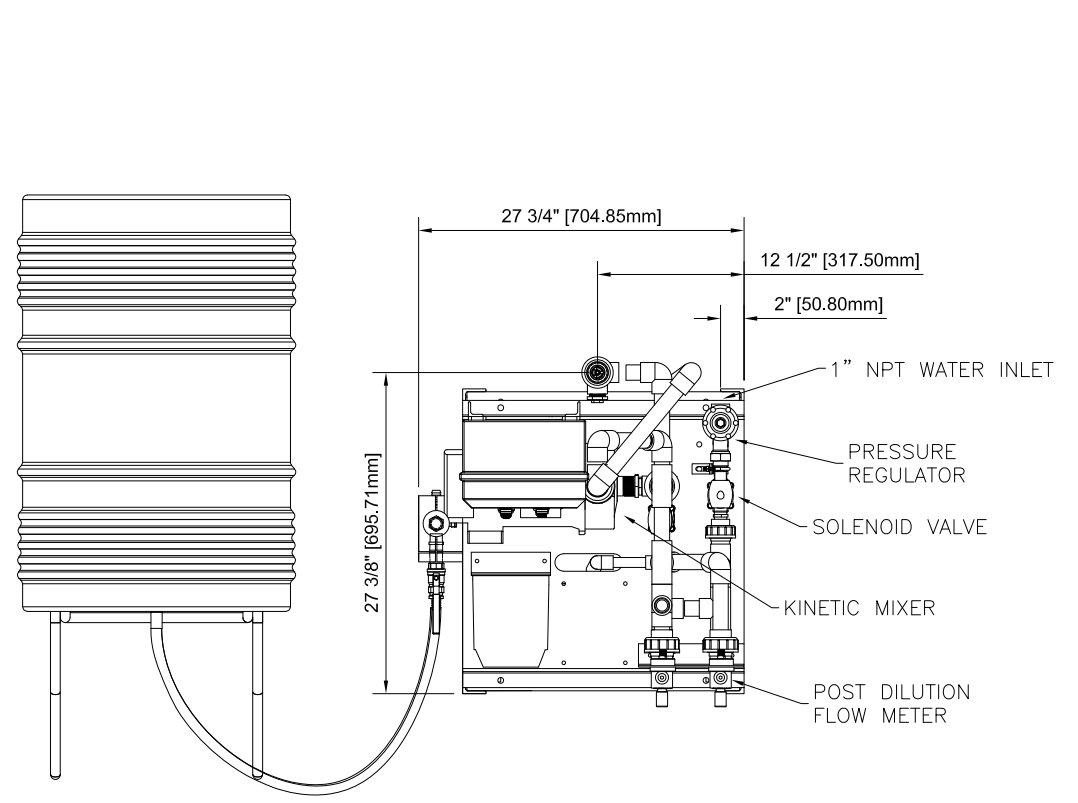

PLAN VIEW

DRAWN ALT APPROVED	4/7/15	CHARTER MACHINE COMPANY 55 WESTER AVE METUCHEN N.J. 08840		
G.E.C. TOLERANCES UNLESS OTHERWISE SPECIFIED FRACTIONAL DIM ±1/64 DECIMAL DIM ±.005 ANGLE ± 1/2 SURFACE FINISH 125				
TITLE ROEDOS L-2.20 POLYMER SYSTEM W/ DRUM DOLLY MACHINE VIEWS		SIZE B	DWG NO. L2.20-02	REV 0
SCALE 3/4" = 1'-0"		SHEET 1 OF 1		