

1" POLYMER SOLUTION OUT  
1" WATER INLET

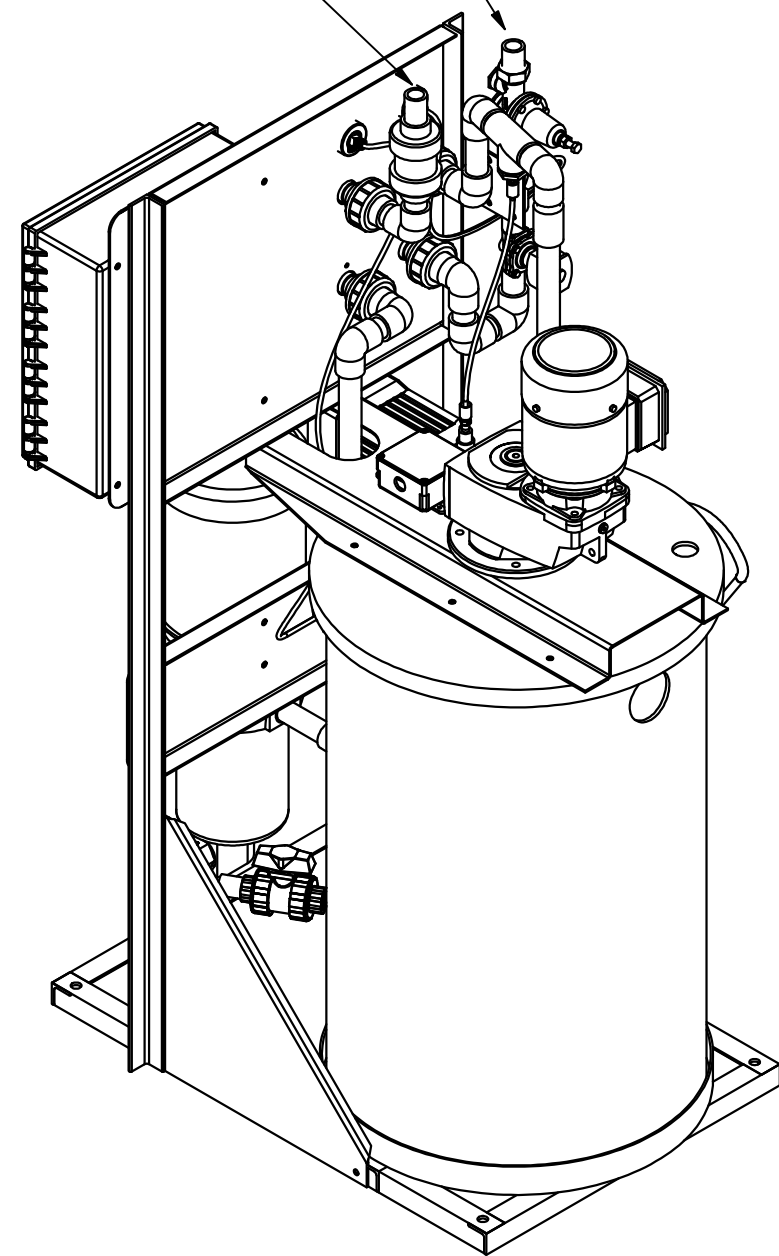

1" WATER INLET  
1" POLYMER SOLUTION OUT

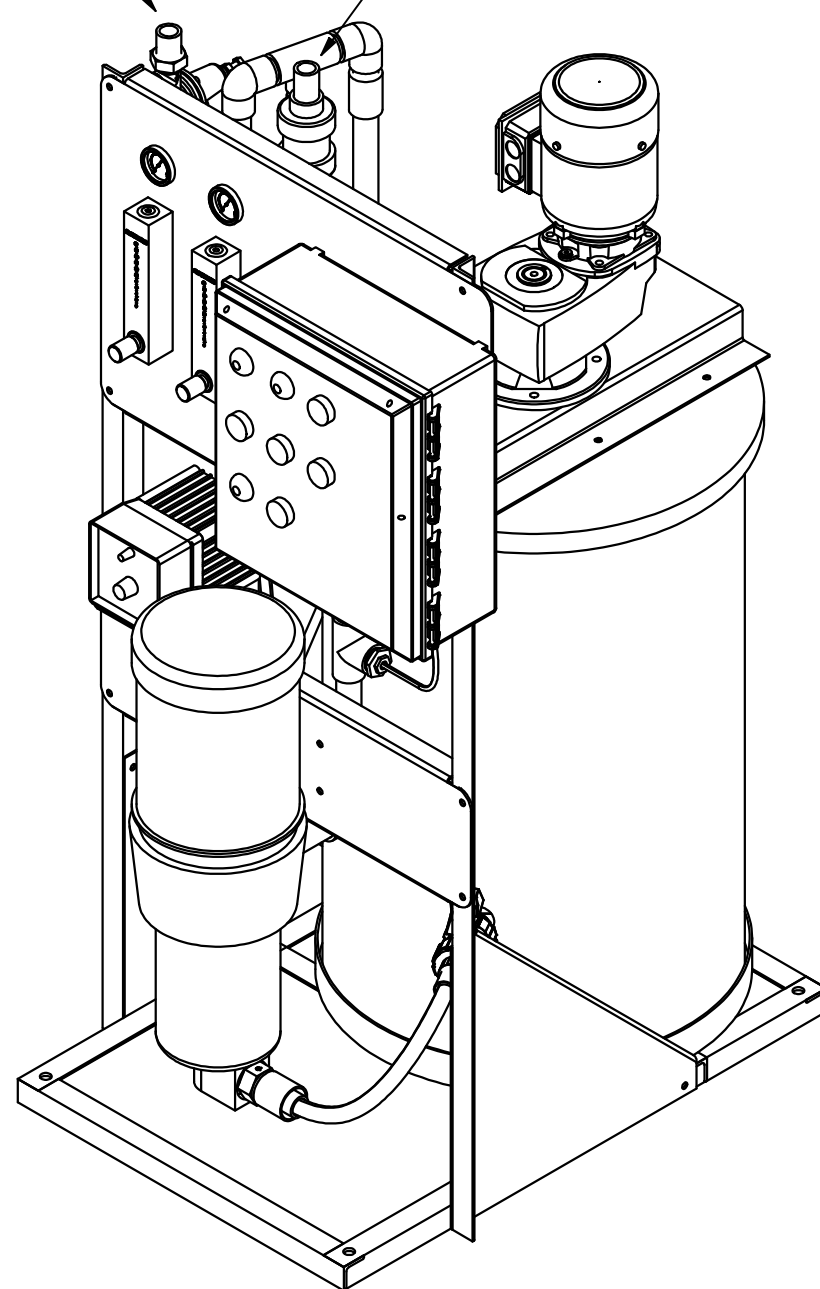

NOTE:  
MINIMUM 20 GPM @ 30 PSI  
WATER SUPPLY REQUIRED

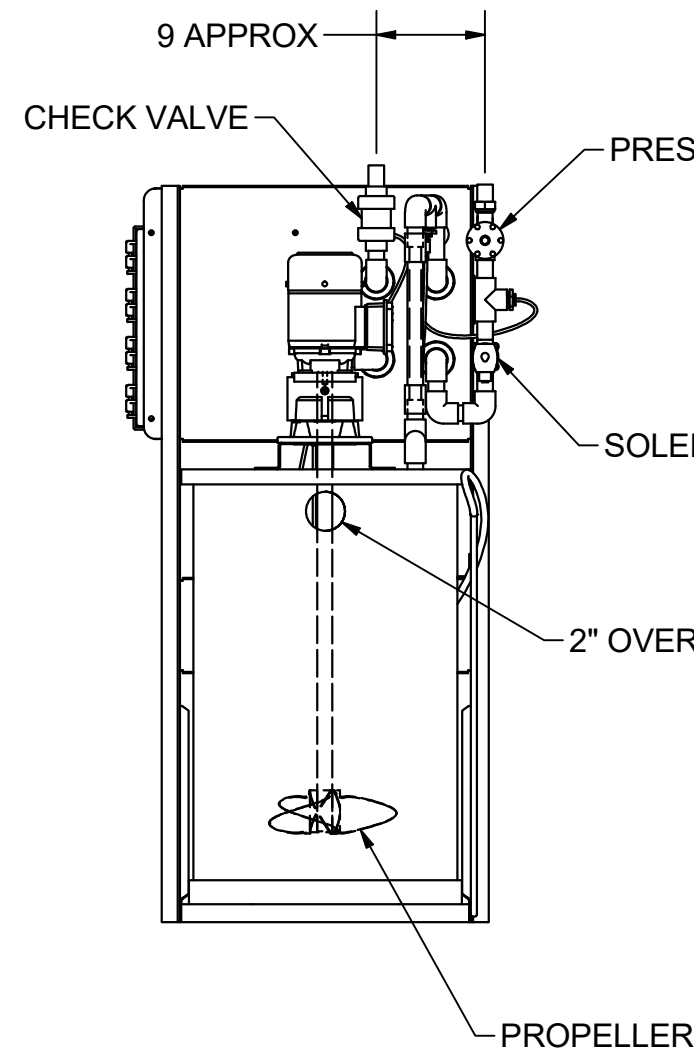
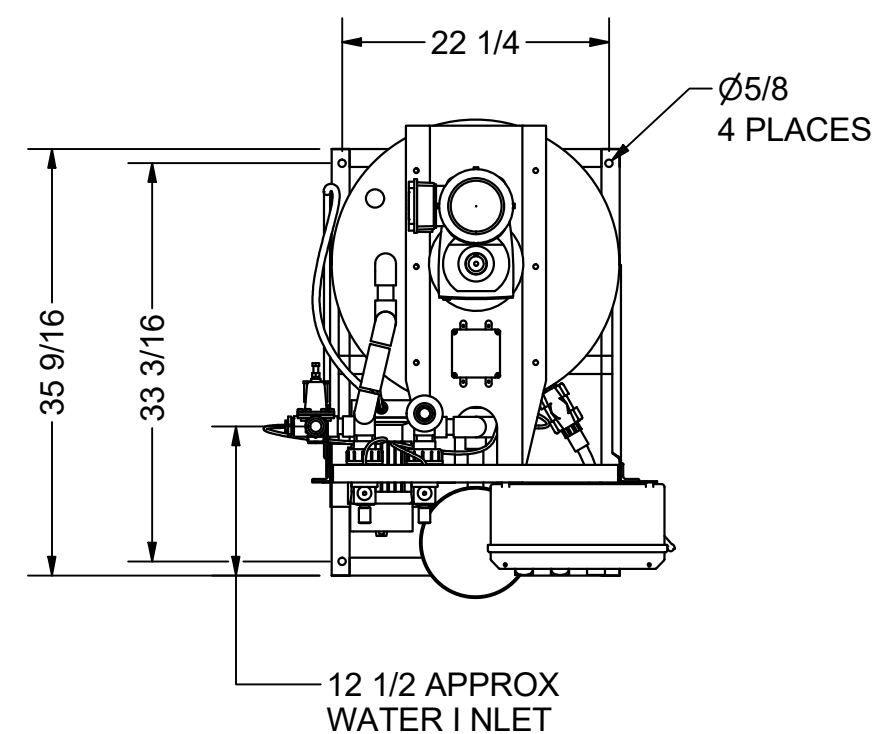

9 APPROX

CHECK VALVE

PRESSURE REGULATOR

SOLENOID VALVE

2" OVERFLOW

PROPELLER

INLINE MIXER

MIXER DRIVE

FULL LEVEL PROBE

55 GAL TANK

LOW ALARM

CONTROL PANEL

METERING PUMP

POLYMER PUMP

FILL LEVEL PROBE

FLOW METER TYP

DILUTION PANEL

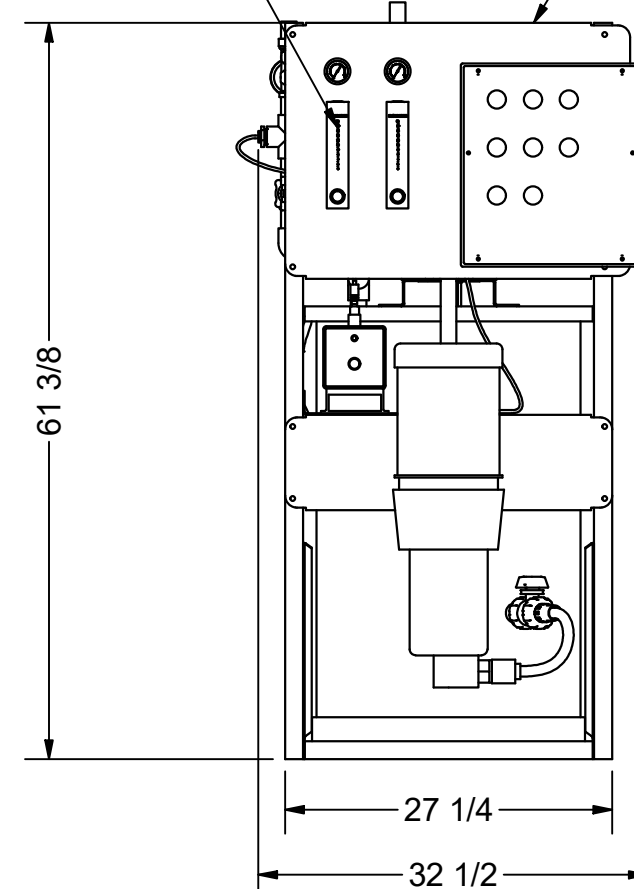

7 7/8  
35 9/16  
39 7/8

NOTE: EDIT THIS DWG. WITH **INVENTOR** ONLY

DRAWN Jerry		12/15/2019		CHARTER MACHINE COMPANY 55 WESTER AVENUE, METUCHEN NJ 08840			
APPROVED							
G.E.C. TOLERANCES UNLESS OTHERWISE SPECIFIED				TITLE L1.1 POLYMER SYSTEM MACHINE VIEWS			
FRACTIONAL DIM ± 1/64				SIZE C		PROJECT	
DECIMAL DIM ± .005				SCALE 1/16		DWG NO L1.1-02	
ANGLE ± 1/2				SHEET 1 OF 1		REV 1	
SURFACE FINISH 125							