

4

3

2

1

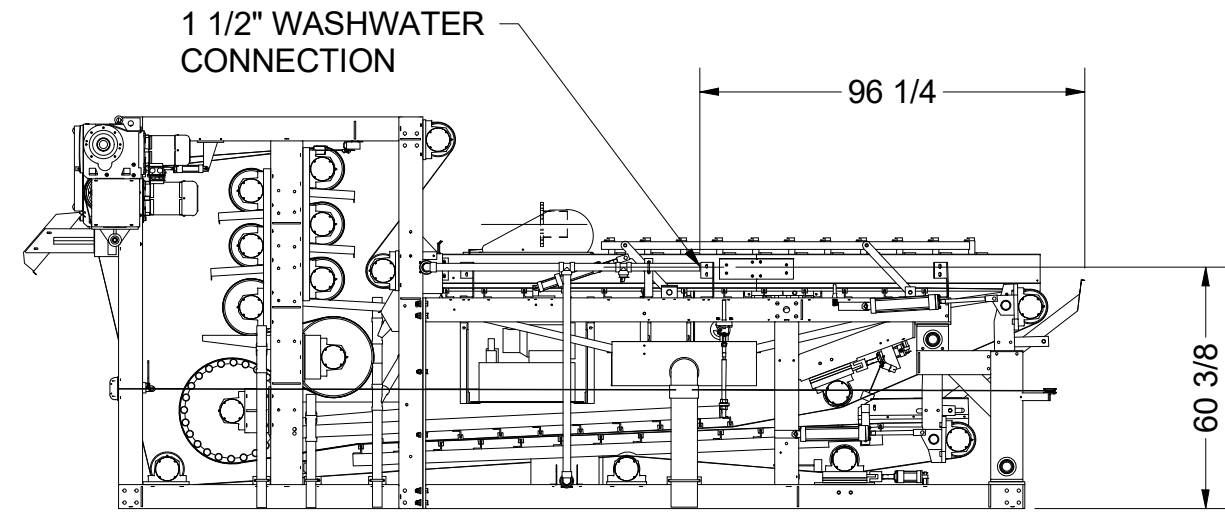

VIEW B-B
SCALE 1"=48"

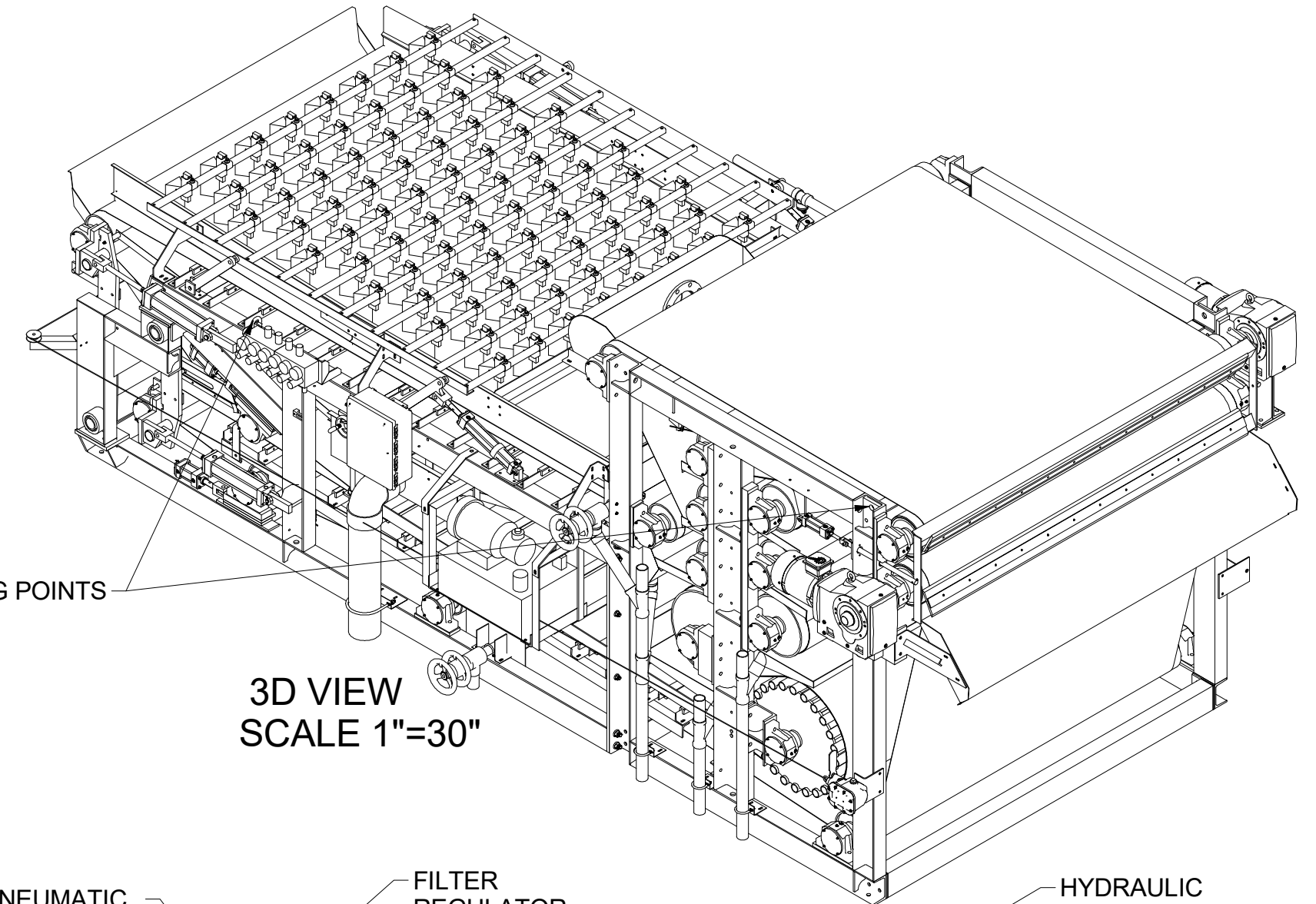

3D VIEW
SCALE 1"=30"

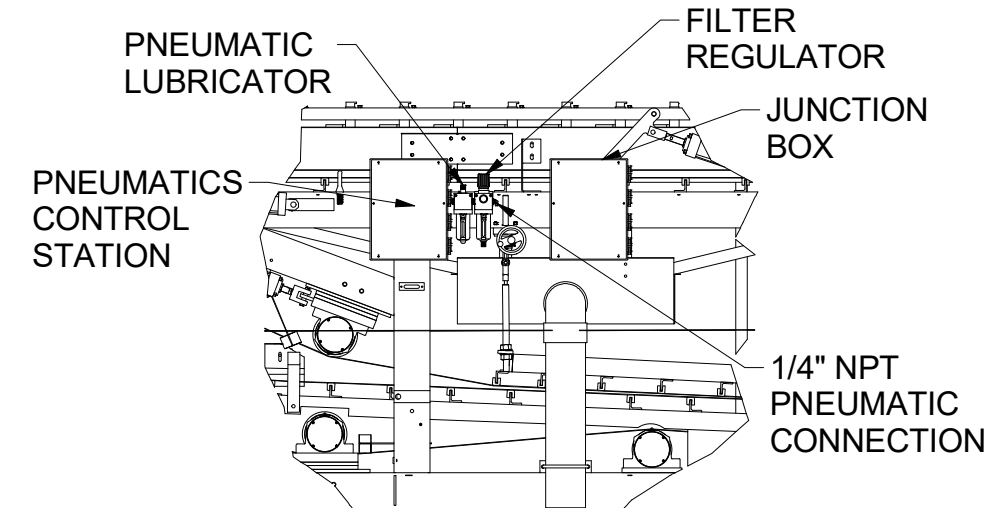
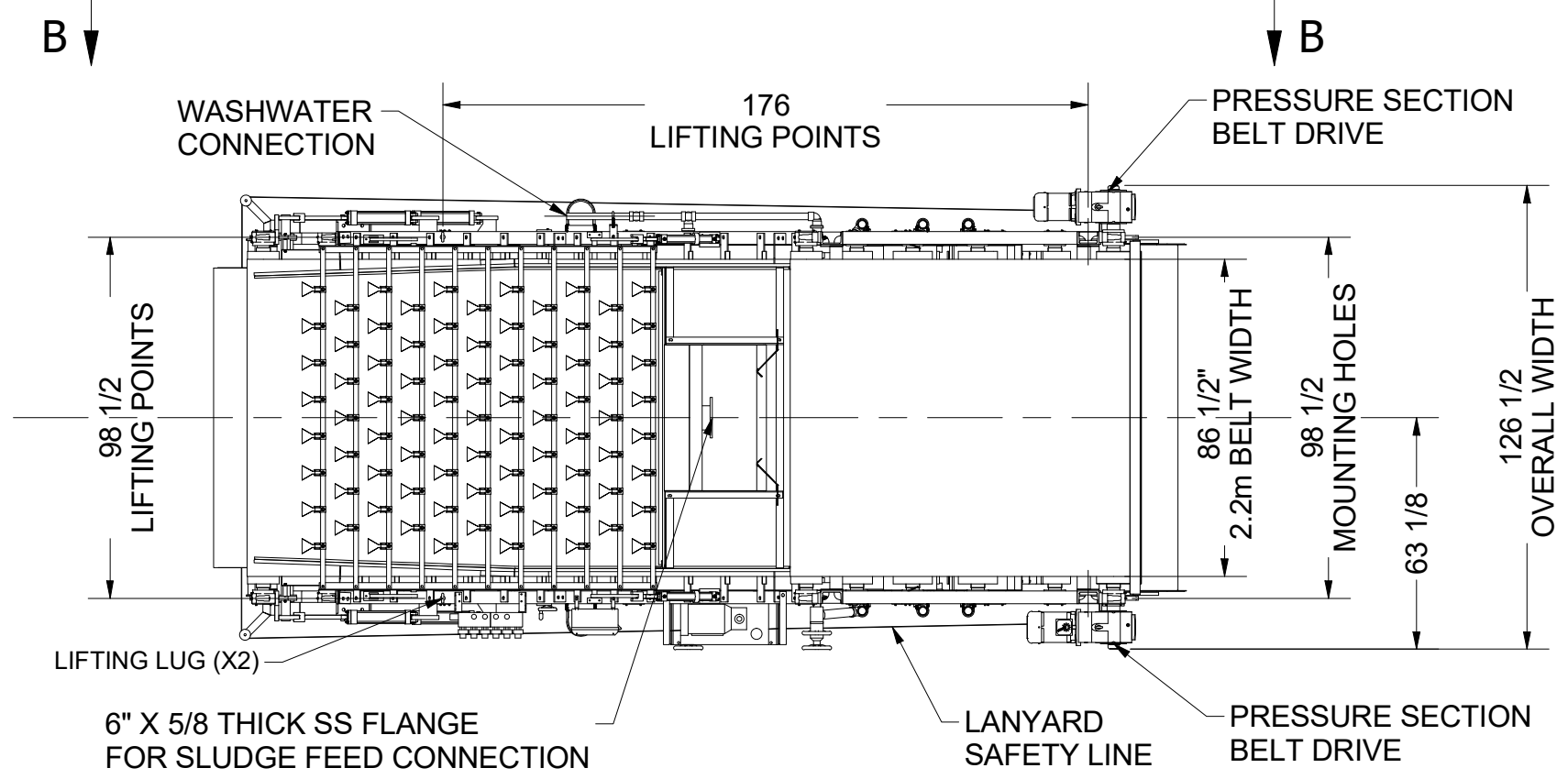

DETAIL C
PNEUMATIC CONTROLS
SCALE 1"=32"

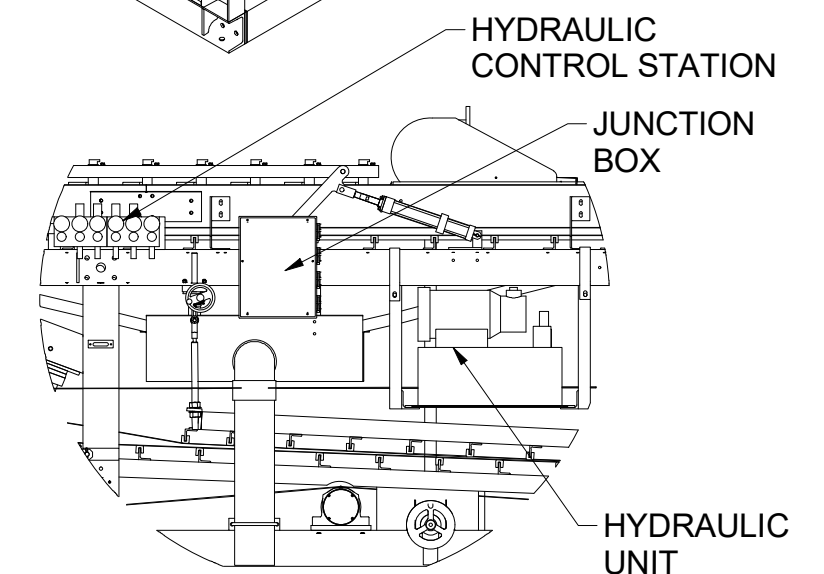

DETAIL C
HYDRAULIC CONTROLS
SCALE 1"=32"

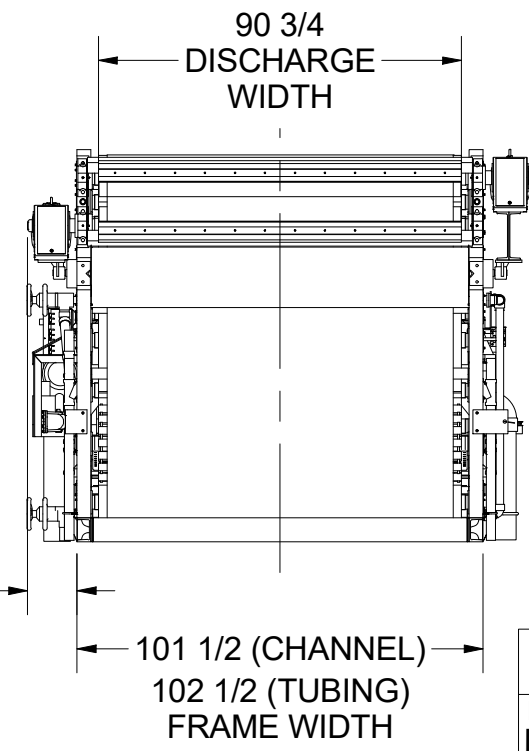
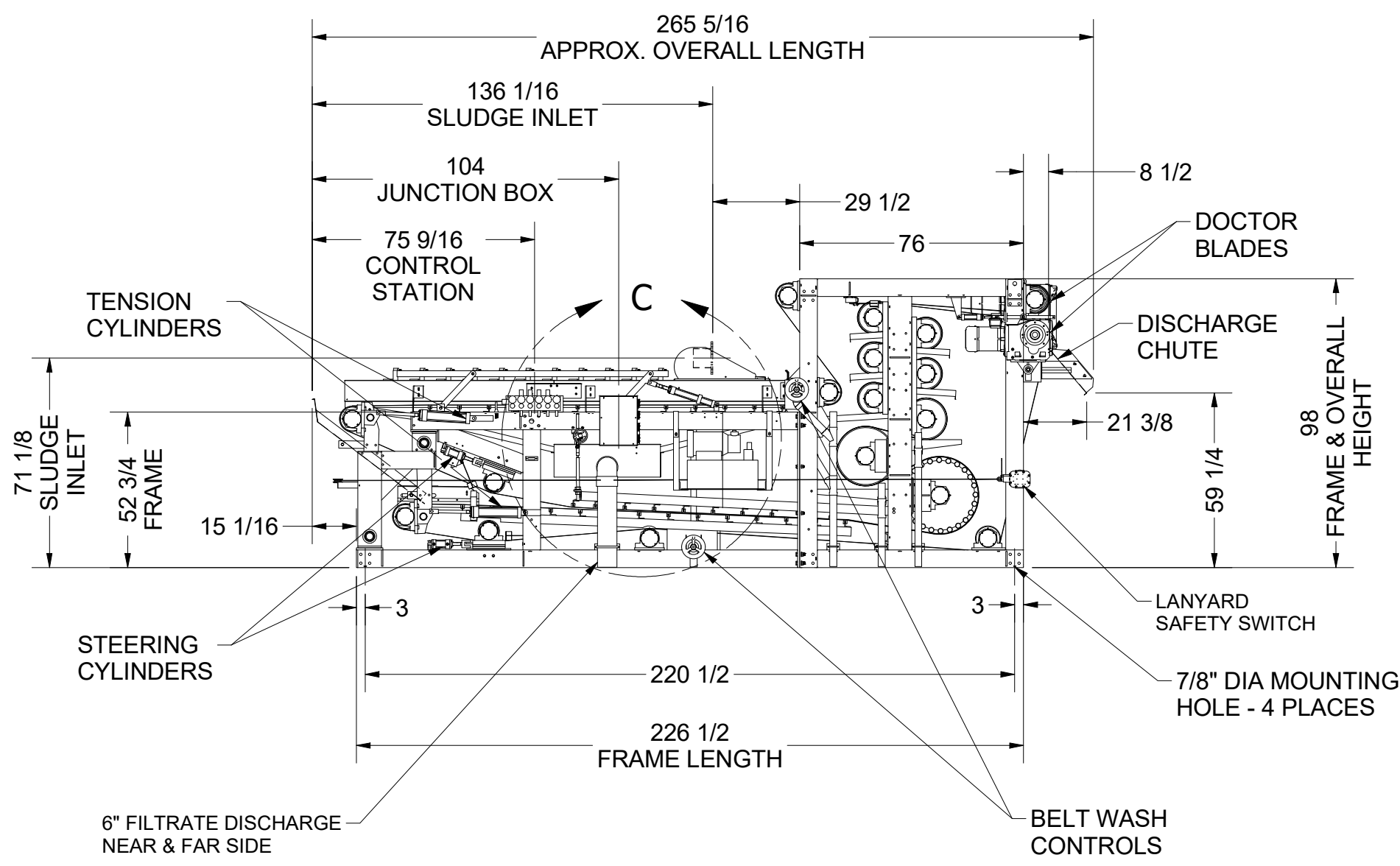

NOTES:
 DETAIL C WILL VARY DEPENDING ON IF SYSTEM UTILIZES PNEUMATICS OR HYDRAULICS
 ALL DIMENSIONS ARE IN INCHES
 LIFTING POINTS ARE MIN 1 1/4" DIA FOR ALL LOCATIONS
 LOCATION OF PLANT WATER CONNECTION FOR BELT WASH SYSTEM VARIES ACCORDING TO LOCATION OF WASH WATER BOOSTER PUMP AND USE OF OPTIONAL WASH WATER RECYCLE.
 APPROXIMATE DRY WEIGHT - 23,000 LBS
 APPROXIMATE WET WEIGHT - 25,000 LBS
 2 PIECE FRAME DESIGN

NOTE: EDIT THIS DWG. WITH **INVENTOR** ONLY

REVISION HISTORY			
REV	DESCRIPTION	DATE	APPROVED
2	COMBINED HYDRAULIC & PNEUMATIC DWGS. UPDATED COMPONENTS. INCLUDED ADDITIONAL VIEWS	10/4/2019	DANIELT

DRAWN DanielT		10/4/2019		CHARTER MACHINE COMPANY 55 WESTER AVENUE, METUCHEN NJ 08840							
APPROVED											
G.E.C. TOLERANCES UNLESS OTHERWISE SPECIFIED				TITLE TOWER PRESS TP22.44S MACHINE VIEWS							
FRACTIONAL DIM ± 1/64				SIZE C		PROJECT		DWG NO TP2244S02		REV 2	
DECIMAL DIM ± .005				SCALE 1"=48"		SHEET 1 OF 1					
ANGLE ± 1/2											
SURFACE FINISH 125											

4

3

2

1