

NOTES:
 STATIC (DRY) WEIGHT = 19,800 LBS.
 DYNAMIC (WET) WEIGHT = 22,200 LBS.

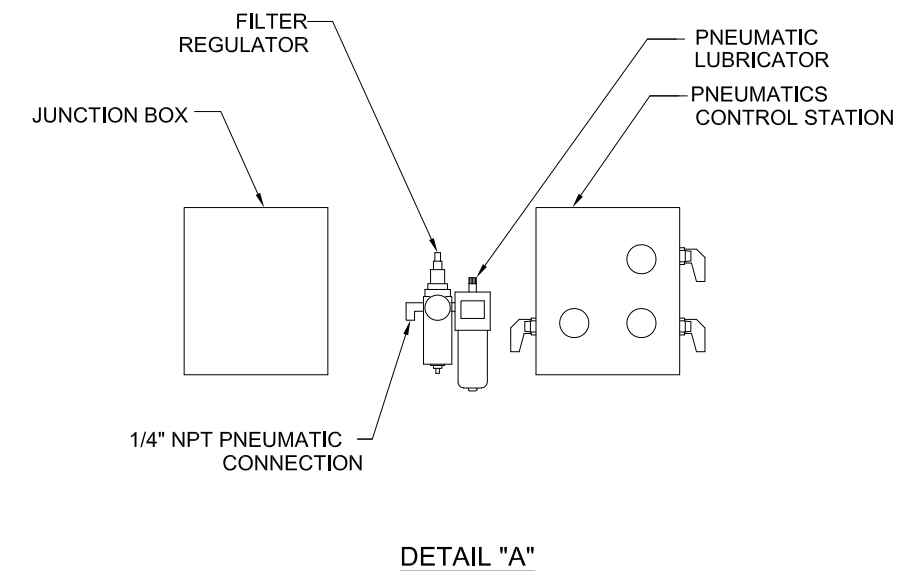
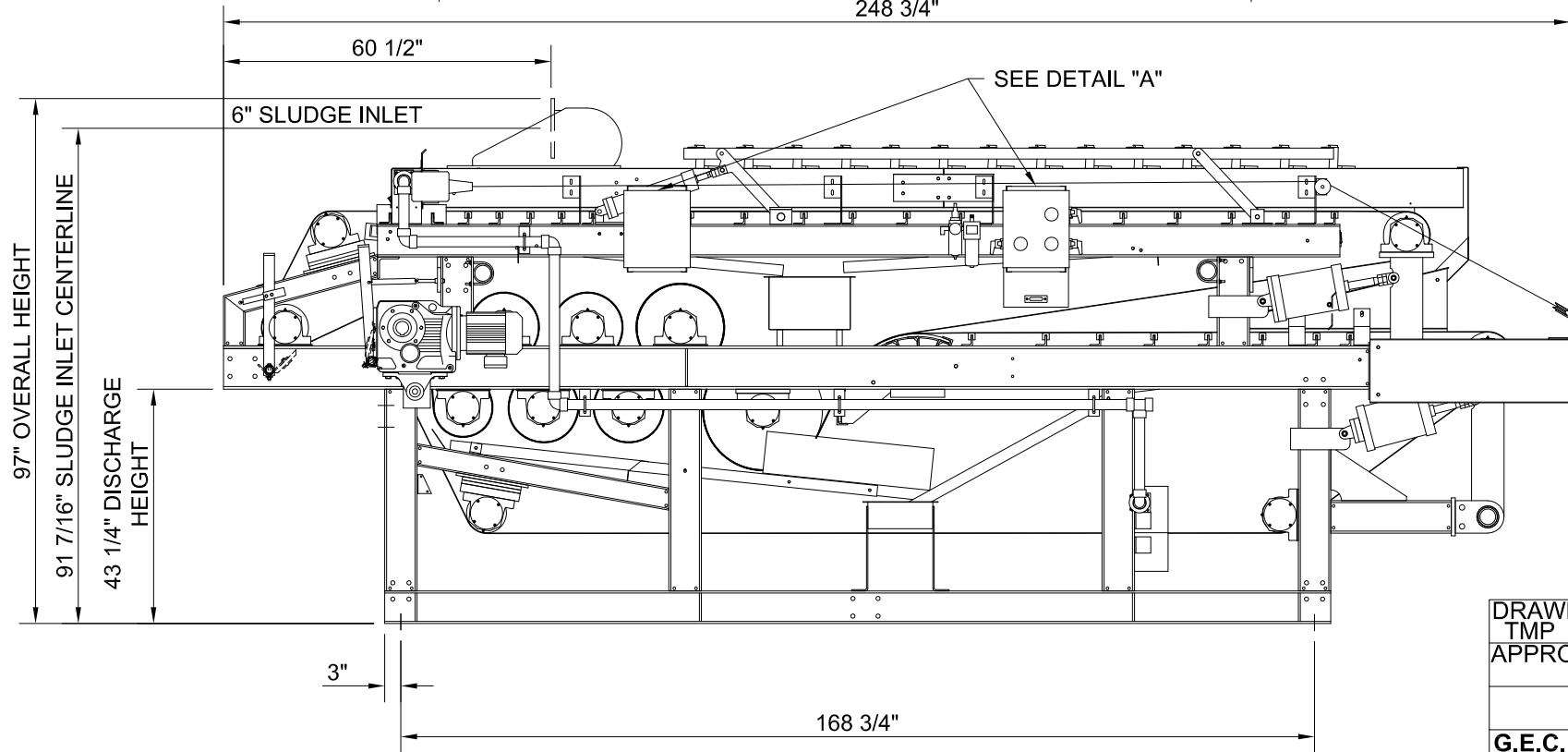

DRAWN TMP	10/11/12	CHARTER MACHINE COMPANY 55 WESTER AVE METUCHEN N.J. 08840	
APPROVED			
G.E.C. TOLERANCES UNLESS OTHERWISE SPECIFIED		TITLE BELT PRESS 22.63 WITH PERFORATED GRID MACHINE VIEWS	
FRACTIONAL DIM ±1/64		SIZE B	REV 2
DECIMAL DIM ±.005		DWG NO. BP22.63-B-912	
ANGLE ± 1/2		SCALE 3/8" = 1'-0"	SHEET 1 OF 1
SURFACE FINISH 125			