

NOTES:
 STATIC (DRY) WEIGHT = 21,300 LBS.
 DYNAMIC (WET) WEIGHT = 23,300 LBS.

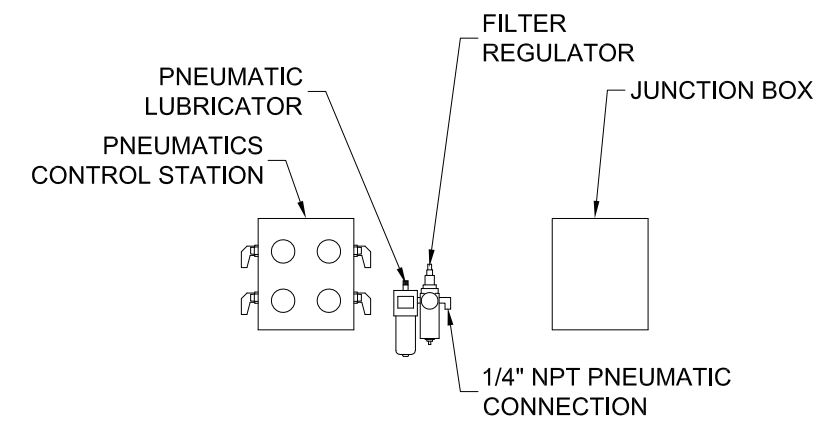

DETAIL "A"

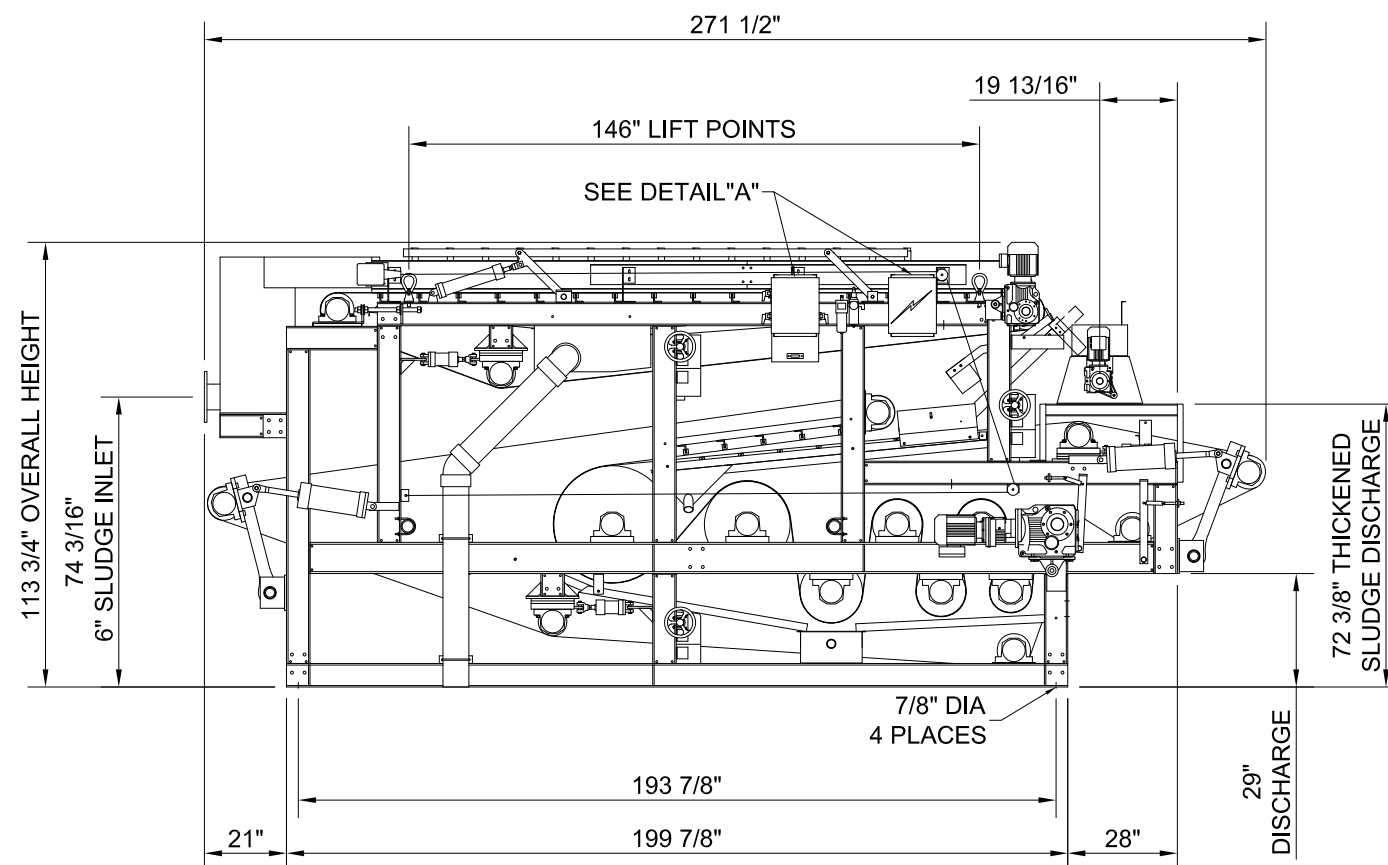

DRAWN TMP	11/14/12	CHARTER MACHINE COMPANY 55 WESTER AVE METUCHEN N.J. 08840	
APPROVED			
G.E.C. TOLERANCES UNLESS OTHERWISE SPECIFIED		TITLE BELT PRESS 17.83 W/ THICKENED SLUDGE CONVEYOR MACHINE VIEWS	
FRACTIONAL DIM	±1/64	SIZE	REV
DECIMAL DIM	±.005	B	1
ANGLE	± 1/2	DWG NO.	
SURFACE FINISH	125	BP17.83-02B	
		SCALE	SHEET 1 OF 1
		1/4" = 1'-0"	