

NOTES:  
 STATIC (DRY) WEIGHT = 21,000 LBS.  
 DYNAMIC (WET) WEIGHT = 23,000 LBS.

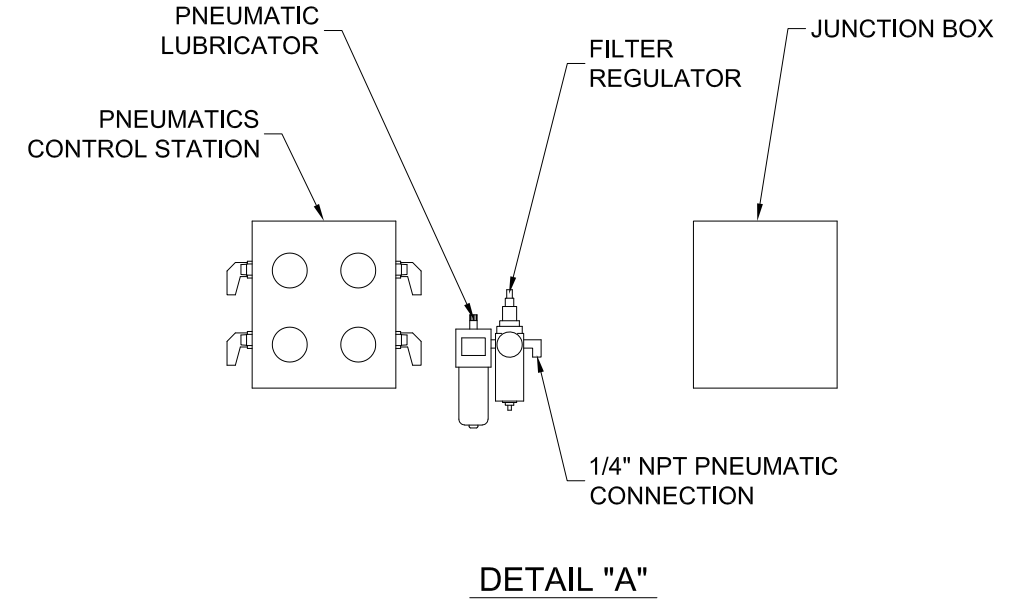
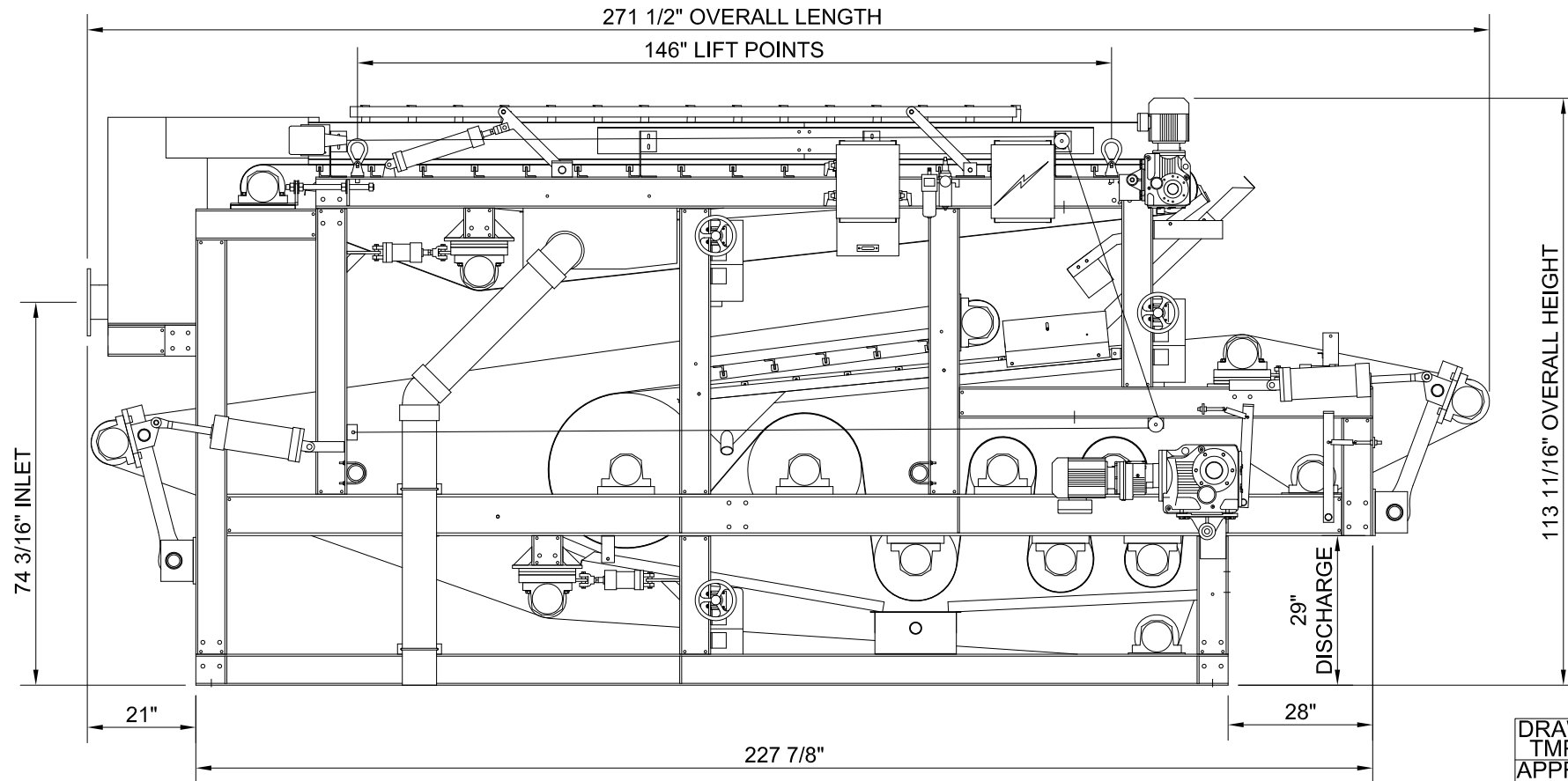

DRAWN TMP	11/14/12	CHARTER MACHINE COMPANY 55 WESTER AVE METUCHEN N.J. 08840		
APPROVED				
<b>G.E.C. TOLERANCES UNLESS OTHERWISE SPECIFIED</b>		TITLE BELT PRESS 17.83 MACHINE VIEWS		
FRACTIONAL DIM ±1/64		SIZE	DWG NO.	REV
DECIMAL DIM ±.005		B	BP17.83-02A	1
ANGLE ± 1/2		SCALE	SHEET 1 OF 1	
SURFACE FINISH 125		3/8" = 1'-0"		