

NOTES:  
 STATIC (DRY) WEIGHT = 18,300 LBS.  
 DYNAMIC (WET) WEIGHT = 20,300 LBS.

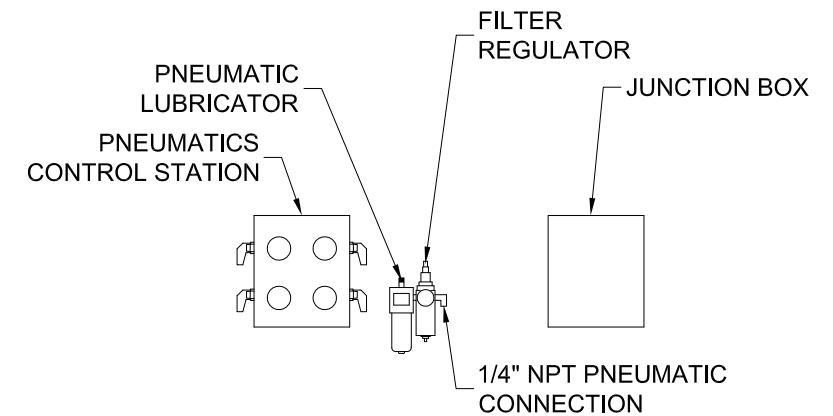
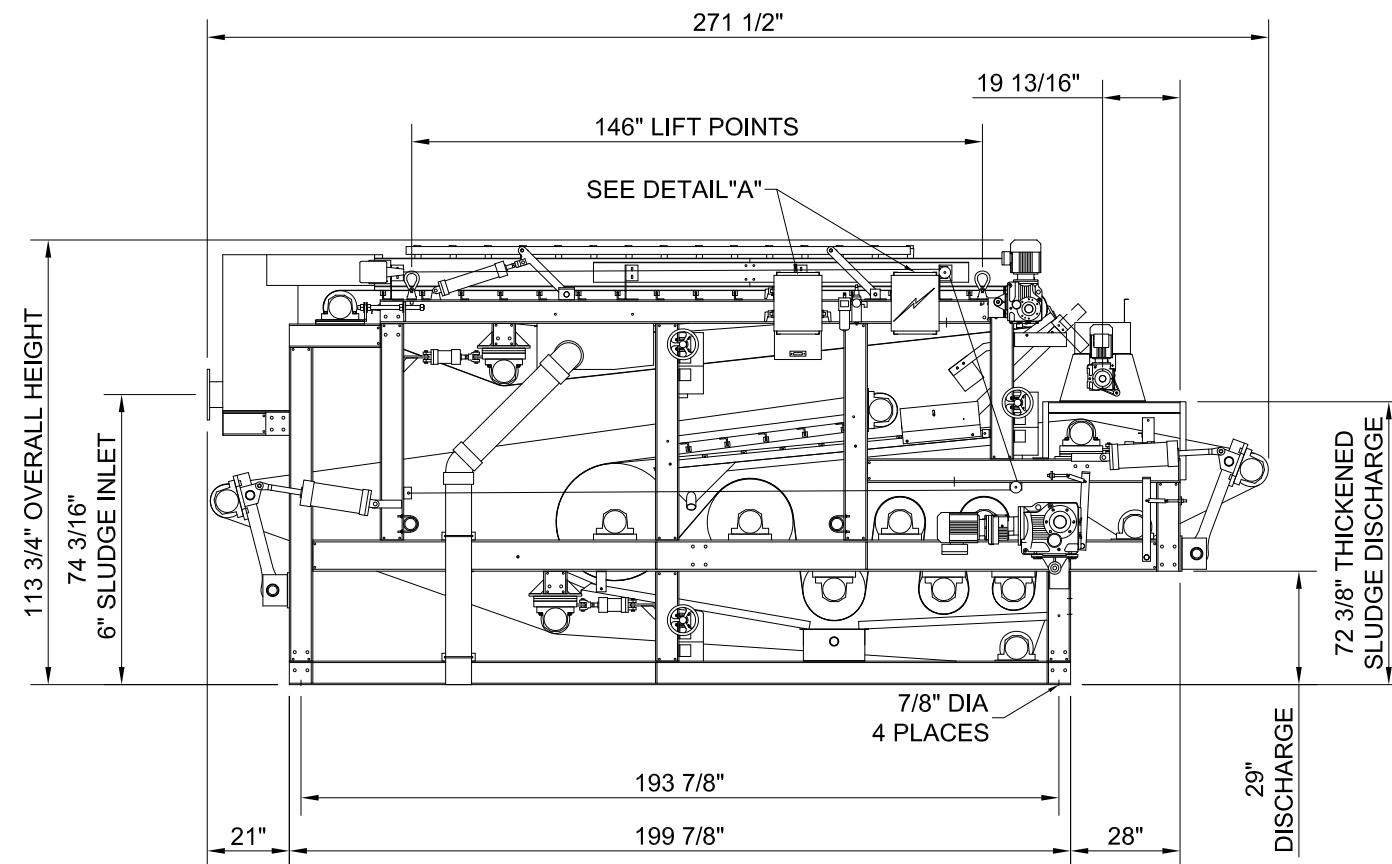

DETAIL "A"

DRAWN TMP	11/14/12	CHARTER MACHINE COMPANY	
APPROVED		55 WESTER AVE METUCHEN N.J. 08840	
<b>G.E.C. TOLERANCES UNLESS OTHERWISE SPECIFIED</b>		TITLE BELT PRESS 12.83 WITH THICKENED SLUDGE CONVEYOR MACHINE VIEWS	
FRACTIONAL DIM	±1/64	SIZE	REV
DECIMAL DIM	±.005	B	1
ANGLE	± 1/2	DWG NO.	
SURFACE FINISH	125	BP12.83-02B	
SCALE		1/4" = 1'-0"	SHEET 1 OF 1