

NOTES:
 STATIC (DRY) WEIGHT = 18,000 LBS.
 DYNAMIC (WET) WEIGHT = 20,000 LBS.

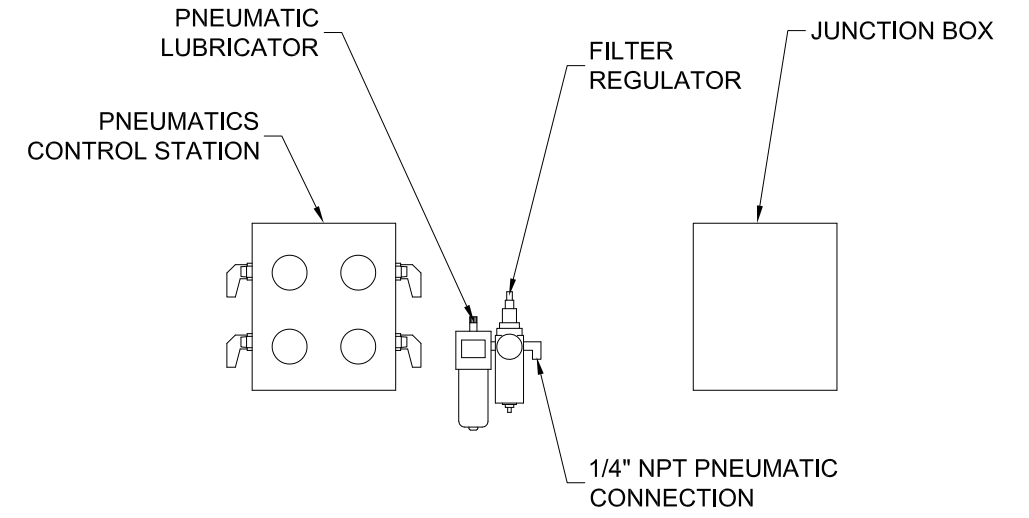
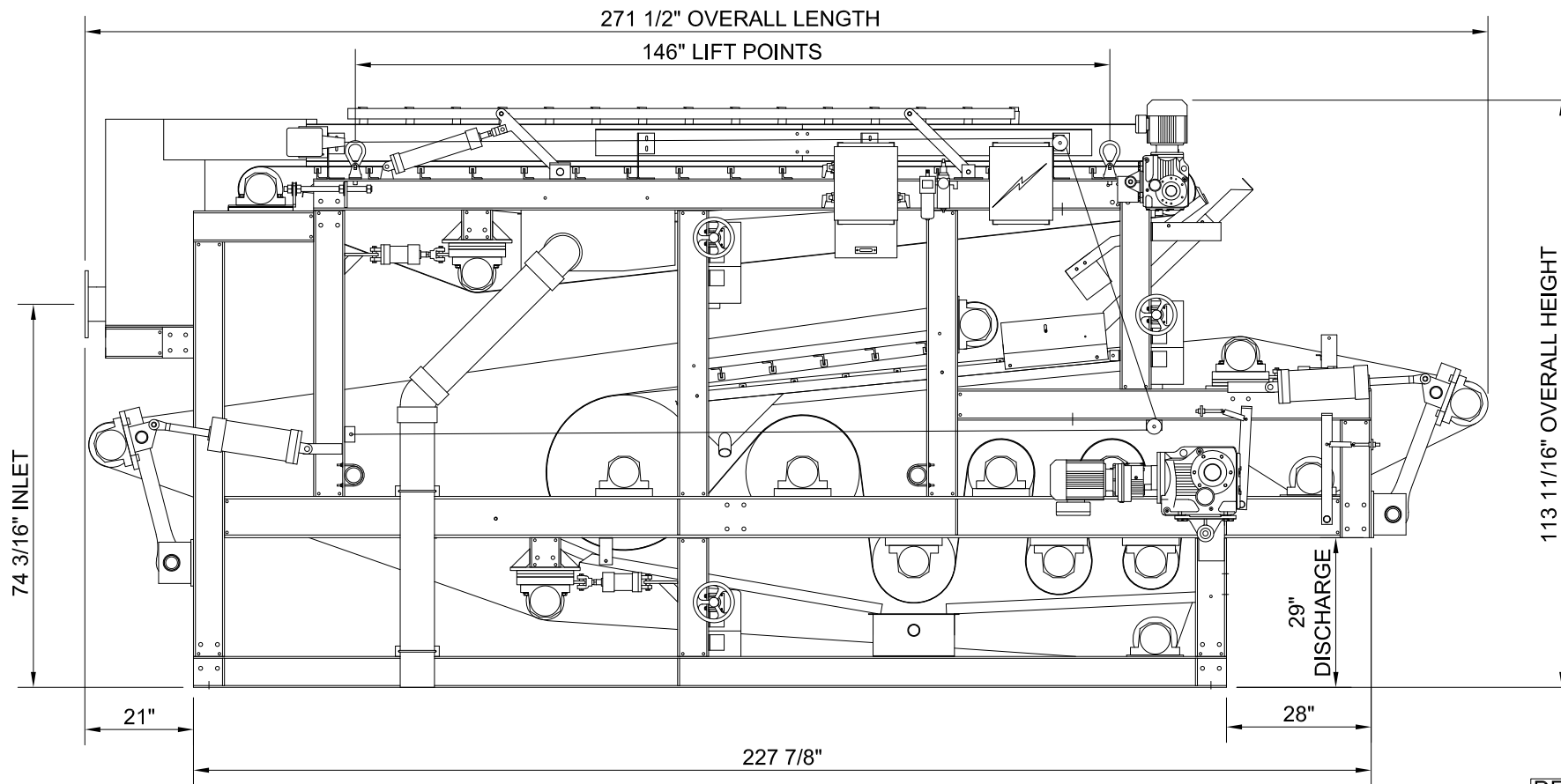

DRAWN TMP	11/14/12	CHARTER MACHINE COMPANY 55 WESTER AVE METUCHEN N.J. 08840	
APPROVED			
G.E.C. TOLERANCES UNLESS OTHERWISE SPECIFIED		TITLE BELT PRESS 12.83 MACHINE VIEWS	
FRACTIONAL DIM ±1/64		SIZE B	REV 1
DECIMAL DIM ±.005		DWG NO. BP12.83-02A	
ANGLE ± 1/2		SCALE 3/8" = 1'-0"	SHEET 1 OF 1
SURFACE FINISH 125			