

NOTES:  
 STATIC (DRY) WEIGHT = 13,620 LBS.  
 DYNAMIC (WET) WEIGHT = 14,830 LBS.

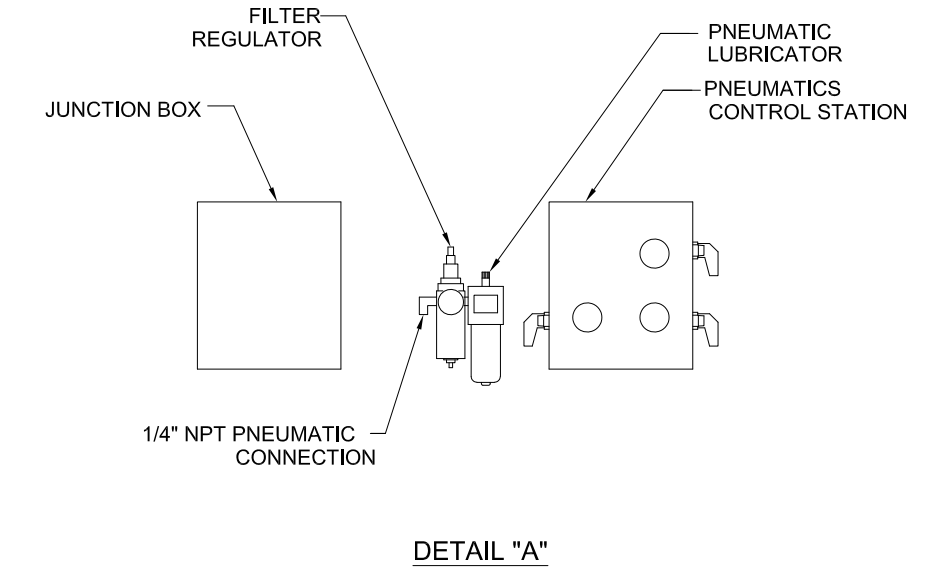
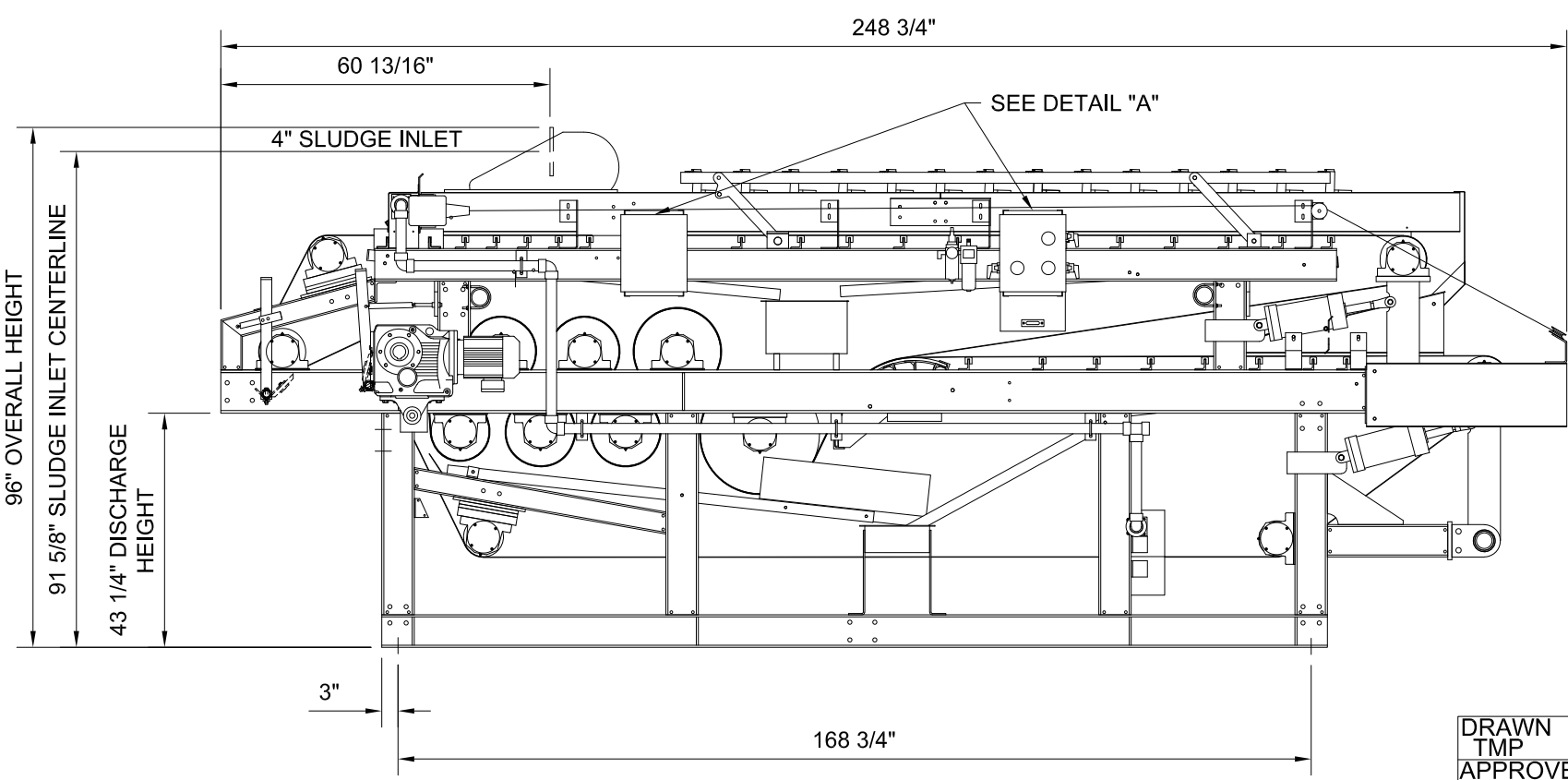

DRAWN TMP	10/11/12	CHARTER MACHINE COMPANY 55 WESTER AVE METUCHEN N.J. 08840	
APPROVED			
G.E.C. TOLERANCES UNLESS OTHERWISE SPECIFIED		TITLE BELT PRESS 12.63 WITH PERFORATED GRID MACHINE VIEWS	
FRACTIONAL DIM ±1/64		SIZE	REV
DECIMAL DIM ±.005		B	2
ANGLE ± 1/2		DWG NO.	
SURFACE FINISH 125		BP12.63-B-912	
SCALE		3/8" = 1'-0"	SHEET 1 OF 1