

DETAIL "A"

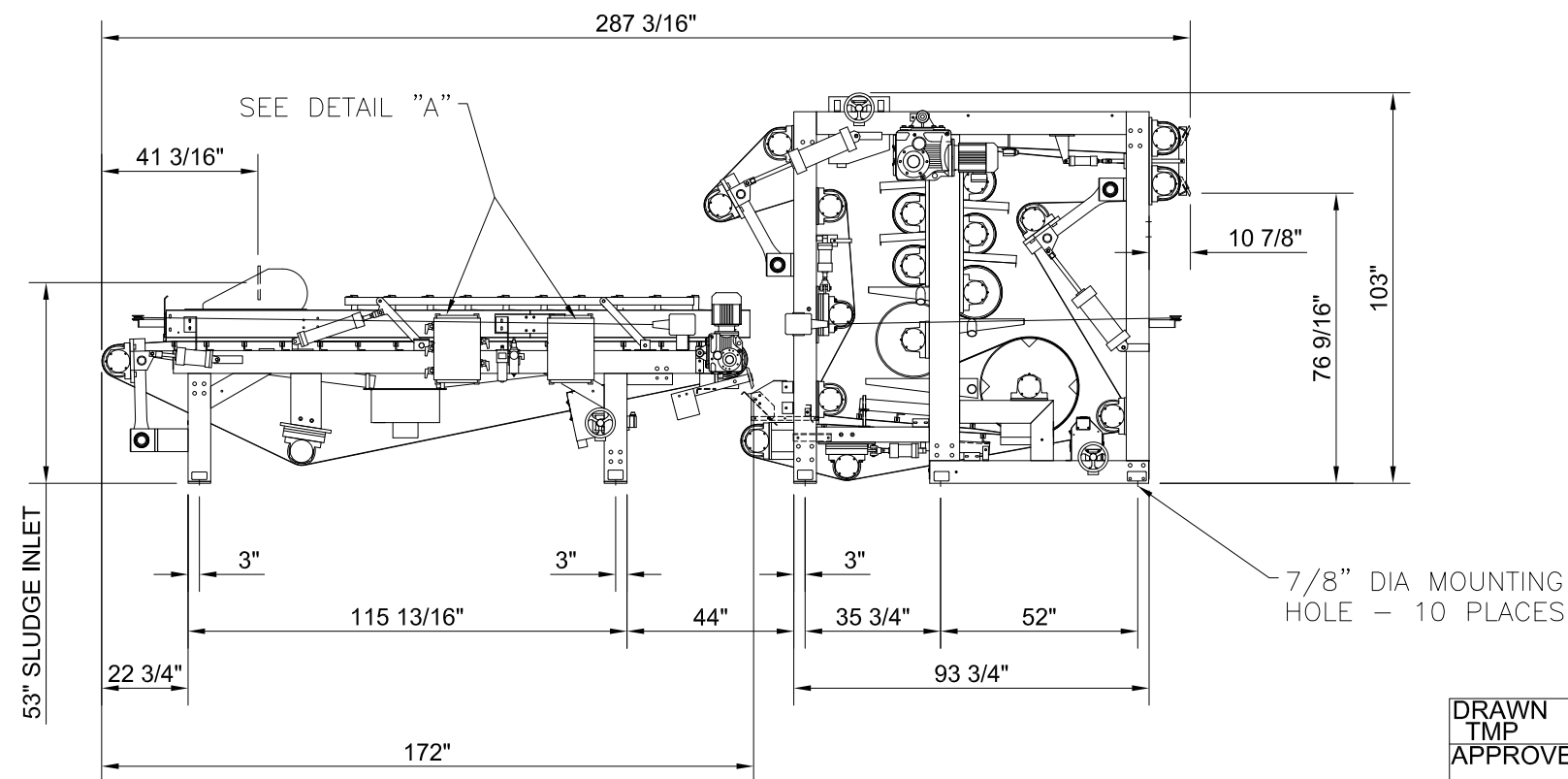

NOTES:

LOCATION OF PLANT WATER CONNECTION FOR BELT WASH SYSTEM VARIES ACCORDING TO LOCATION OF WASH WATER BOOSTER PUMP AND USE OF OPTIONAL WASH WATER RECYCLE.

LIFTING POINTS ARE MIN. 1 1/4" DIA FOR ALL LOCATIONS.

GBT SECTION DRY WEIGHT = 4,300 LBS.
GBT SECTION WET WEIGHT = 5,320 LBS.

PRESSURE SECTION DRY WEIGHT = 10,600 LBS.
PRESSURE SECTION WET WEIGHT = 11,790 LBS.

DRAWN TMP	6/19/13	CHARTER MACHINE COMPANY 55 WESTER AVE METUCHEN N.J. 08840	
APPROVED			
G.E.C. TOLERANCES UNLESS OTHERWISE SPECIFIED		TITLE 3-BELT TOWER PRESS 12.93S MACHINE VIEWS	
FRACTIONAL DIM ±1/64		SIZE	DWG NO.
DECIMAL DIM ±.005		B	3BTP12.93S-02
ANGLE ± 1/2		SCALE	REV
SURFACE FINISH 125		1/4" = 1'-0"	4
		SHEET 1	OF 1